

Cyclone XML

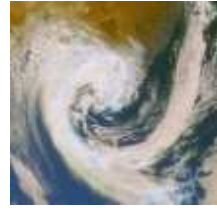

Cyclone XML Specification

Version 1.0
4 June 2008



Australian Government
Bureau of Meteorology



Authors: Elizabeth Ebert (BOM/CAWCR),
Zoltan Toth (NCEP/EMC),
Mike Charles (NCEP/EMC),
Gil Ross (Met Office)

DOCUMENT CONTROL

| Version No | Issue Date | Description | Author |
|-------------------|-------------------|--|---------------|
| 0.1 | 19 March 2008 | Initial draft | E. Ebert |
| 0.2 | 27 March 2008 | source attribute added to some elements | E. Ebert |
| 1.0 | 4 June 2008 | Numerous modifications – see http://www.bom.gov.au/bmrc/projects/THORPEX/CXML/index.html for details | E. Ebert |

TABLE OF CONTENTS

1 INTRODUCTION.....4

1.1 BACKGROUND4

1.2 DESCRIPTION.....5

1.3 VERSIONS.....6

1.4 GOVERNANCE6

2 FULL DATA MODEL.....6

3 DESCRIPTION OF CXML DATA ELEMENTS.....6

3.1 FRAMEWORK ELEMENTS6

3.2 METADATA ELEMENTS6

3.3 DISTURBANCE DATA ELEMENTS.....6

3.4 CYCLONEDATA ELEMENTS6

4 SCHEMA FOR CXML V.1.06

5 CXML SAMPLE FILES.....6

5.1 TROPICAL CYCLONE ANALYSIS6

5.2 TROPICAL CYCLONE FORECAST6

5.3 TROPICAL CYCLONE FORECAST FROM NWP.....6

5.4 ENSEMBLE TC FORECAST FROM NWP6

APPENDIX 1: RECOMMENDED DATA UNITS IN CXML6

1 Introduction

1.1 Background

Observationally based analysis and subjective and numerical forecast information on tropical cyclones is routinely produced by National Hydro-Meteorological Centers (NHMCs), a number of Regional Specialized Meteorological Centers (RSMCs), Tropical Cyclone Warning Centers (TCWCs), and other Numerical Weather Prediction (NWP) centers and forecast agencies. The different producing centers use a variety of formats to convey tropical cyclone related information.

At the 6th WMO International Workshop on Tropical Cyclones (IWTC-VI; HKO 2006), the tropical cyclone research and operational communities recommended the improved sharing of information within these communities:

The WMO should take all necessary action to:

- improve the communication between operational centres and facilitate the dissemination of all tropical cyclone-related NWP products, such as the deterministic and ensemble forecasts (including the full set of ensemble runs),
- make them available to all RSMCs, TCWCs and researchers in real-time.

WMO should investigate the most appropriate ways to achieve this goal:

- coordinate with the NWP and major operational centres (RSMCs and TCWCs) in order to define a set of resolvable tropical cyclone characteristics to be provided and timely disseminated by the NWP centres through the GTS (e.g. centre location, minimum sea level pressure, max wind, wind radii by quadrants, etc...) and define the *appropriate standardised format*,
- and/or find a WMO-sponsored dedicated reference centre (similarly to what has been done with the Severe Weather Information Centre for the dissemination of the analysis and forecast products issued by the main operational centres) able to host and maintain a single global data base of the tropical cyclone forecasts originating from the different NWP centres.

Meanwhile, the THORPEX community is preparing plans for the development of the Global Interactive Forecast System (GIFS 2007), which is a multi-center ensemble based NWP system for improvements in the prediction of high impact weather events. GIFS will be based on real time access to and processing of forecast data produced at different NWP centers and RSMCs. The upcoming THORPEX Pacific-Asian Regional Campaign (T-PARC) during 2008-2009 (THORPEX 2007), with its focus on tropical cyclogenesis, landfall, recurvature, extra-tropical transitioning, and extra-tropical storm development and propagation, presents an opportunity for quick advances in the next year or two. The confluence and importance of these activities was recognized by the TC community in the following high-priority recommendation:

IWTC-VI considers that the tropical cyclone community should engage and cooperate with the THORPEX activities of relevance to the tropics, especially the THORPEX Pacific Asian Regional Campaign (T-PARC) and the THORPEX Interactive Grand Global Ensemble/Global Interactive Forecast System (TIGGE/GIFS), which aims in particular to develop generic probabilistic forecast products from a global archive of ensemble forecasts originating from a number of NWP centres.

The tropical cyclone and the THORPEX communities have decided to capture this unique opportunity to work together, with tropical cyclone forecasting as a proving ground for testing new GIFS procedures and techniques designed to eventually improve all high impact weather forecasts.

Cyclone XML Specification

The efficient exchange of ensemble and other tropical cyclone forecast information among all interested and participating parties (NHMSs, RSMCs, NWP centers, etc.) is essential for the improved services the tropical cyclone and GIFS communities envision.

After reviewing currently used formats for tropical cyclone related information, it became clear that eXtensible Markup Language (XML) would be ideally suited for the exchange of cyclone related data because of its descriptive nature. XML is an internet standard and is used to convey other types of meteorological information. "Cyclone XML" (CXML) has been designed specifically to convey tropical (and other) storm related analysis and forecast information.

This document provides the specification of the design and use of CXML. The CXML web site <http://www.bom.gov.au/bmrc/projects/THORPEX/CXML/index.html> holds the latest version of this document, the CXML schema, some sample CXML files, links to XML libraries, code in various languages for reading CXML data, and user feedback.

1.2 Description

Cyclone XML incorporates features from existing formats for exchanging data on tropical cyclones:

- WMO's **B**inary **U**niversal **F**ormat for **R**epresentation (BUFR),
- WMO's **C**haracter form for the **R**epresentation and **E**Xchange of data (CREX),
- NRL's **A**utomated **T**ropical **C**yclone **F**orecasting system (ATCF),

It also incorporates additional variables suggested by many scientists and forecasters from the tropical cyclone community. In particular, the capability to represent ensemble forecasts has specifically been built into CXML.

Figure 1 shows the conceptual data model for a forecast of a cyclone. The "header" segment contains metadata about the product, including its name, the production center, creation date, etc. The "data" segment contains information on a single "disturbance" (cyclone), where each "fix" refers to its location at a particular time. The "cycloneData" segment within each fix contains data on the storm's central pressure, maximum wind speed, and other relevant information.

This same data model applies equally well to an analyzed cyclone, where the data segment would then specify type="analysis". If only one time instance is given then only one fix is included, while multiple fixes would correspond to multiple time instances ("best track" data, for example).

In the case of a global NWP model, there may be more than one disturbance predicted in the domain (Figure 2). Each disturbance has its own set of fixes with cycloneData.

The data model for an ensemble prediction system (Figure 3) is an extension of the one for a global NWP model, where now there are several ensemble members (e.g., several forecasts). Each ensemble member may contain one or more disturbances.

CXML includes much more information than shown in Figs. 1-3. To allow maximum flexibility in the representation and exchange of data, only a small subset of possible data elements are required while the remainder are optional. This means that the CXML files can be as brief or as lengthy as required for a particular application.

Tree diagrams showing the full data model for CXML are given in Section 2. Details of the elements (tags) used in CXML are given in Section 3. Section 4 lists the CXML schema, with sample CXML files presented in Section 5.

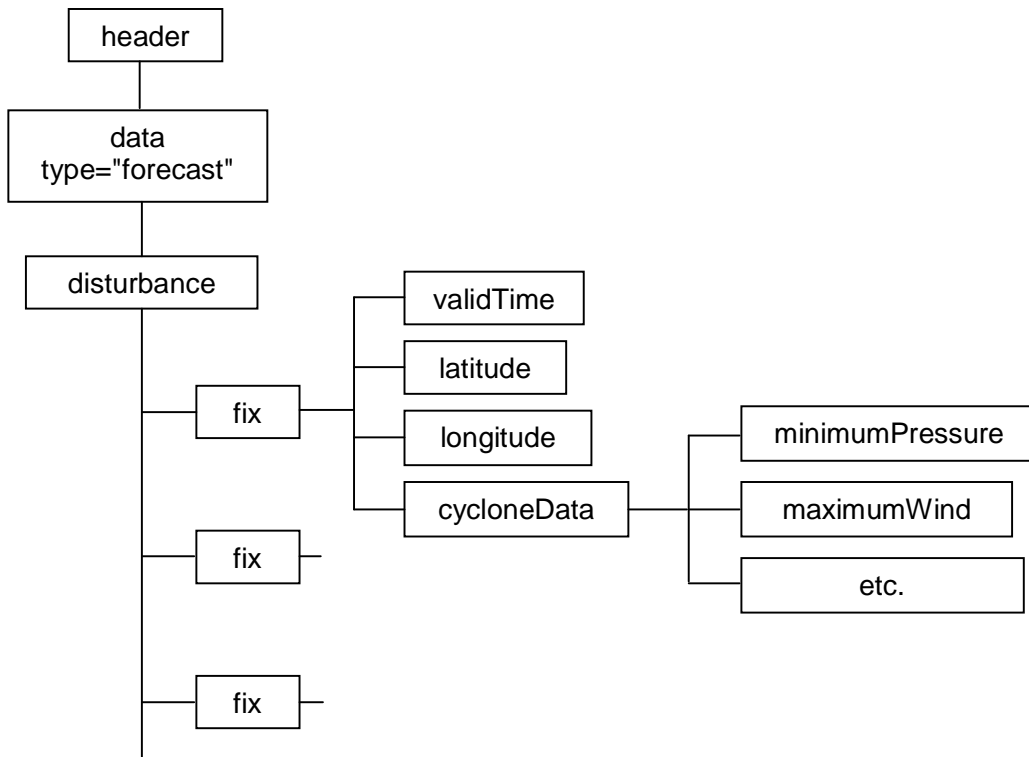

Fig. 1. Conceptual data model for a forecast of a tropical cyclone. An analysis with multiple fixes such as "best track" data could also be represented by this data model, with the data tag having type="analysis". An analysis at a single time would have only one fix.

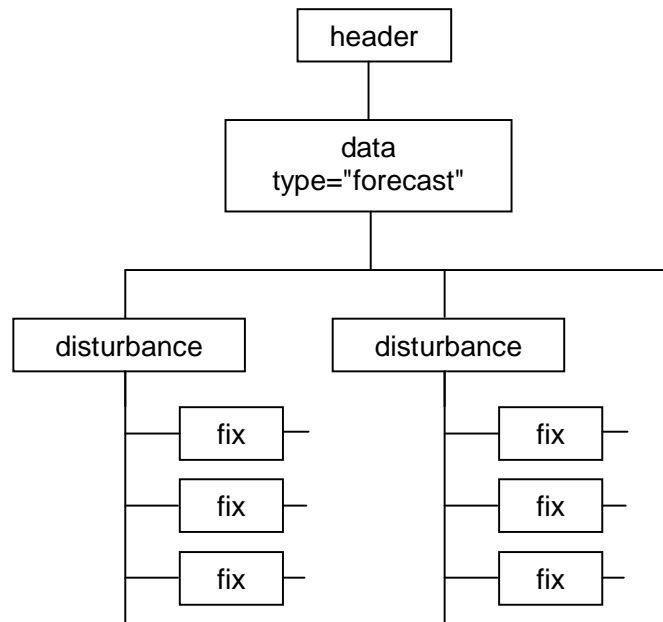

Fig. 2. Conceptual data model for a forecast from a global NWP model that may predict more than one tropical cyclone.

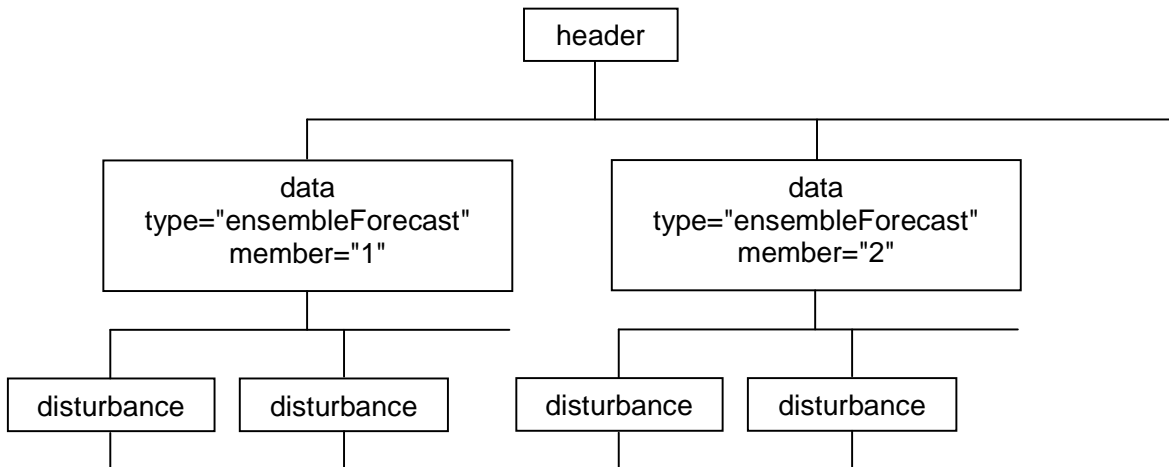

Fig. 3. Conceptual data model for a forecast from a global ensemble prediction system in which each ensemble member may predict more than one tropical cyclone.

1.3 Versions

CXML may be updated from time to time, with each update assigned a unique version number. Minor updates will be given an incremental version number (e.g., version 2.1 updated to 2.2), while major updates will be given a full version number (e.g. version 2.2 updated to 3.0). Schemas for older versions of CXML will remain available online so that applications using those versions will function properly.

1.4 Governance

The responsibility for CXML maintenance and improvement belongs to ...

2 Full data model

These tree diagrams show the full data model for CXML version 1.0. The data elements are shown in bold font. Italicized data elements have attributes of units (required) and precision (optional). The plain text in the lower portion of the boxes list additional attributes with those printed in italics being required. The symbols to the upper left of each box indicate the requirements for each element. Details for the header and fix segments are given on the following pages.

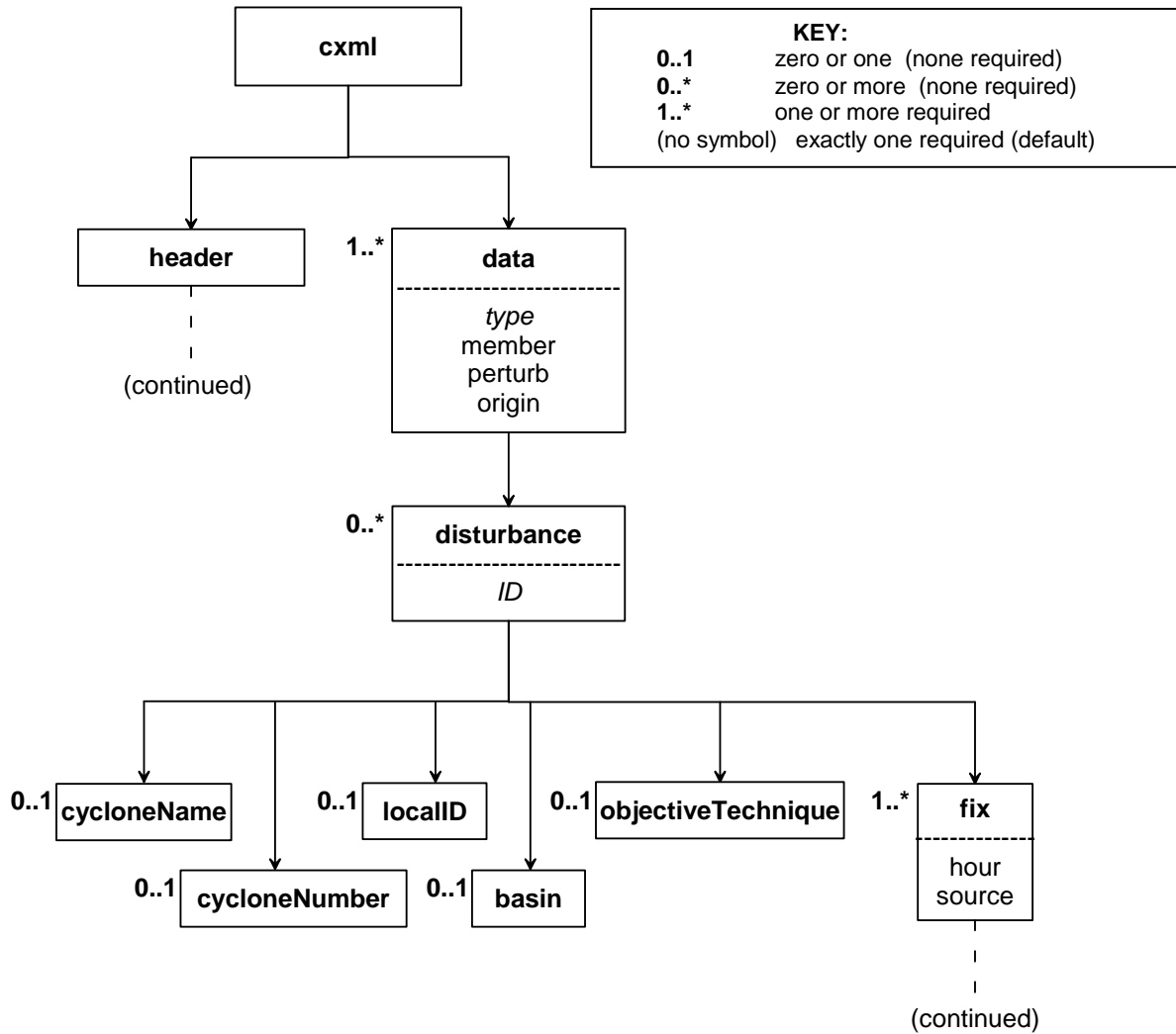

Data model for CXML version 1.0.

Cyclone XML Specification

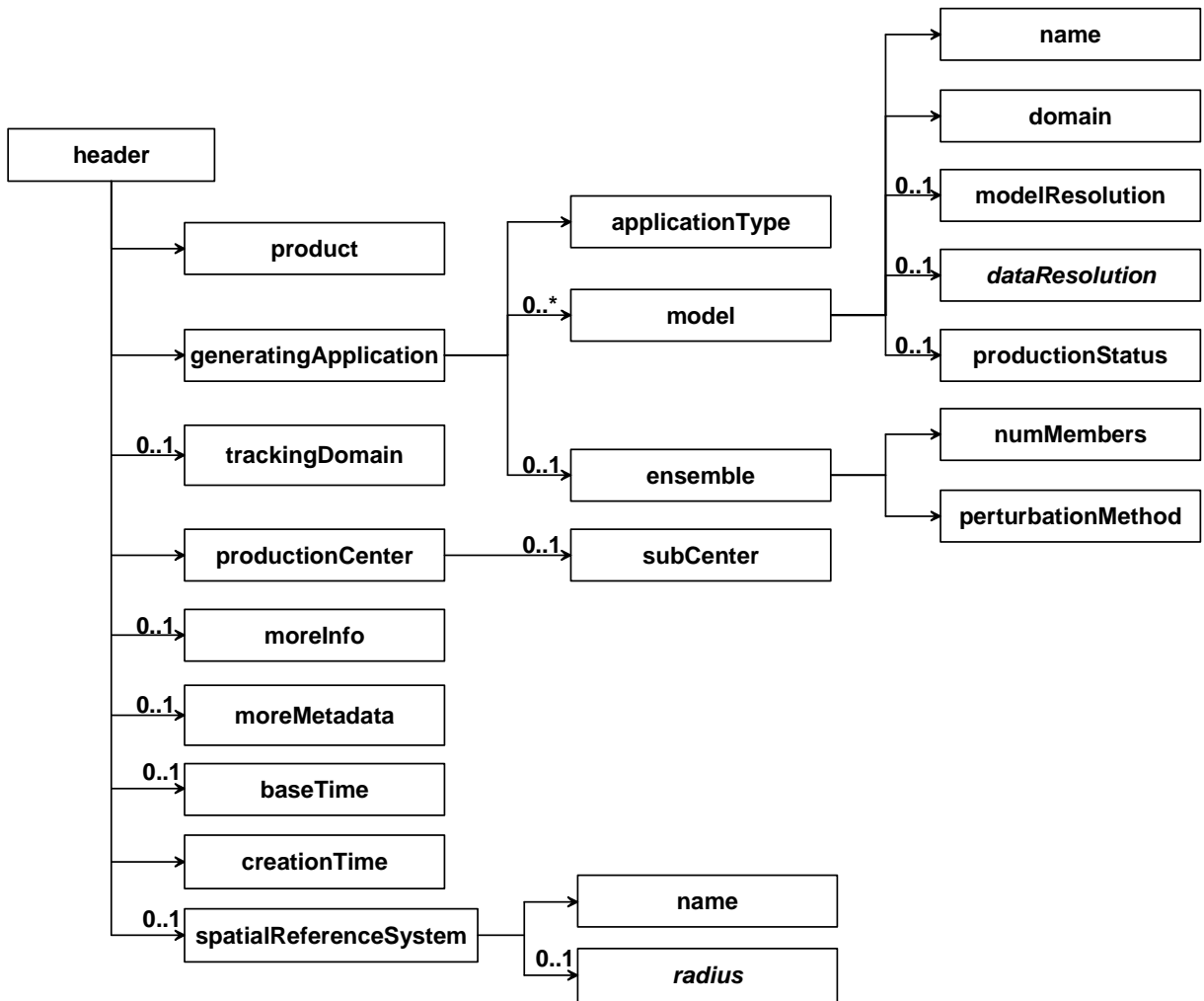

Data model for header segment.

Cyclone XML Specification

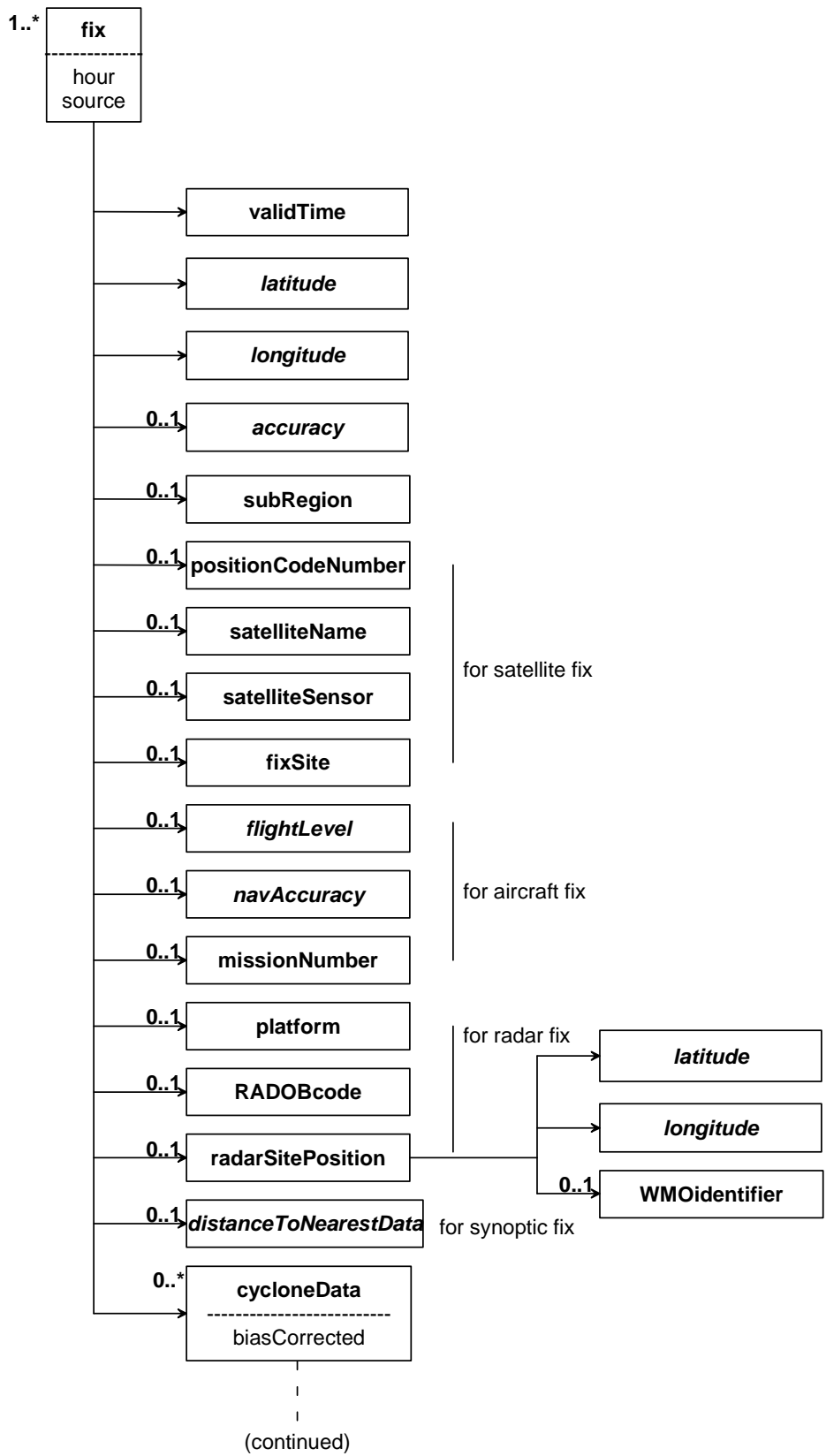

Data model for fix.

Cyclone XML Specification

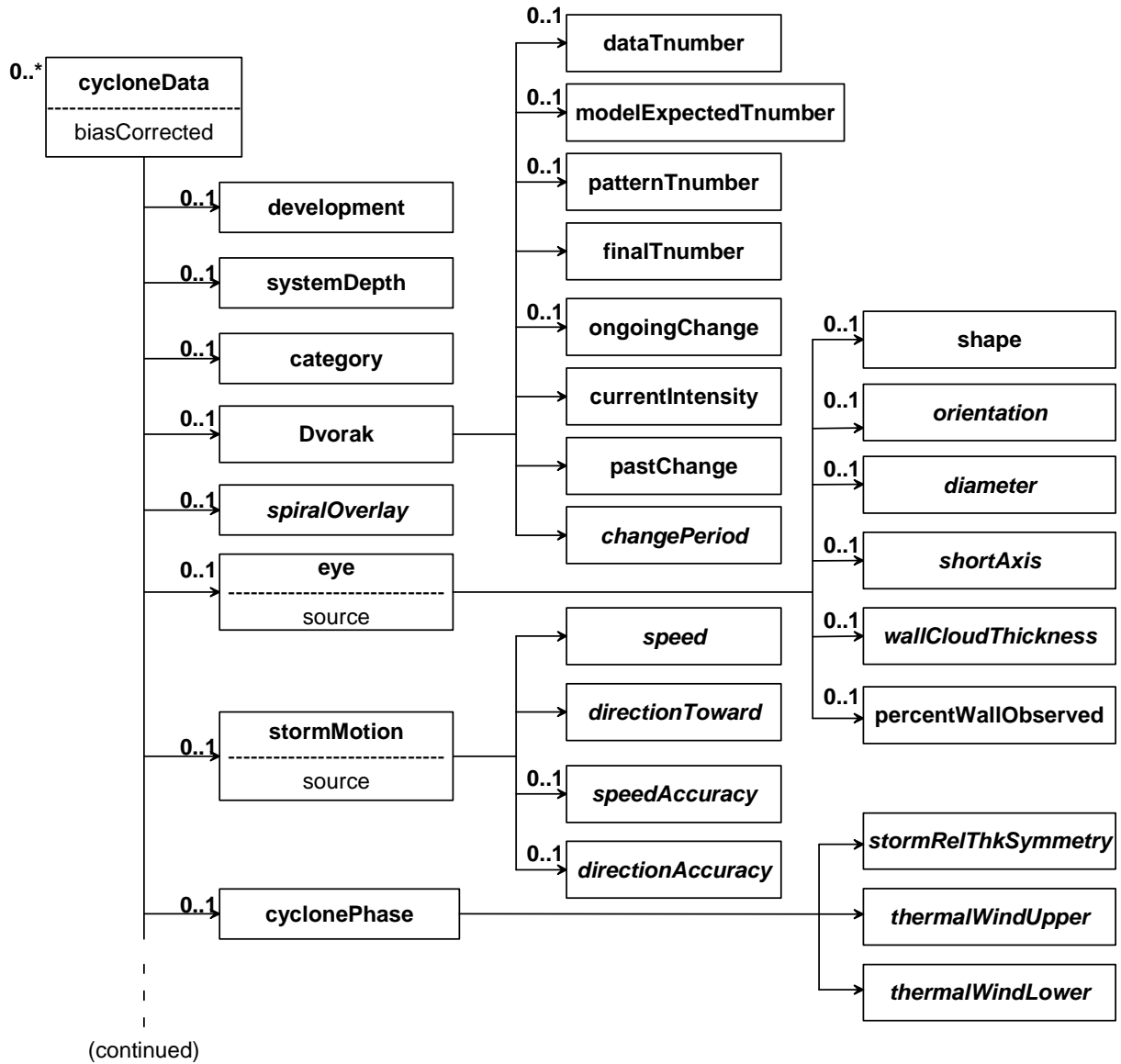

Data model for the cyclone data segment: cyclone characteristics. The level 1 elements (<development>, <systemDepth>, etc.) may be given in any order.

Cyclone XML Specification

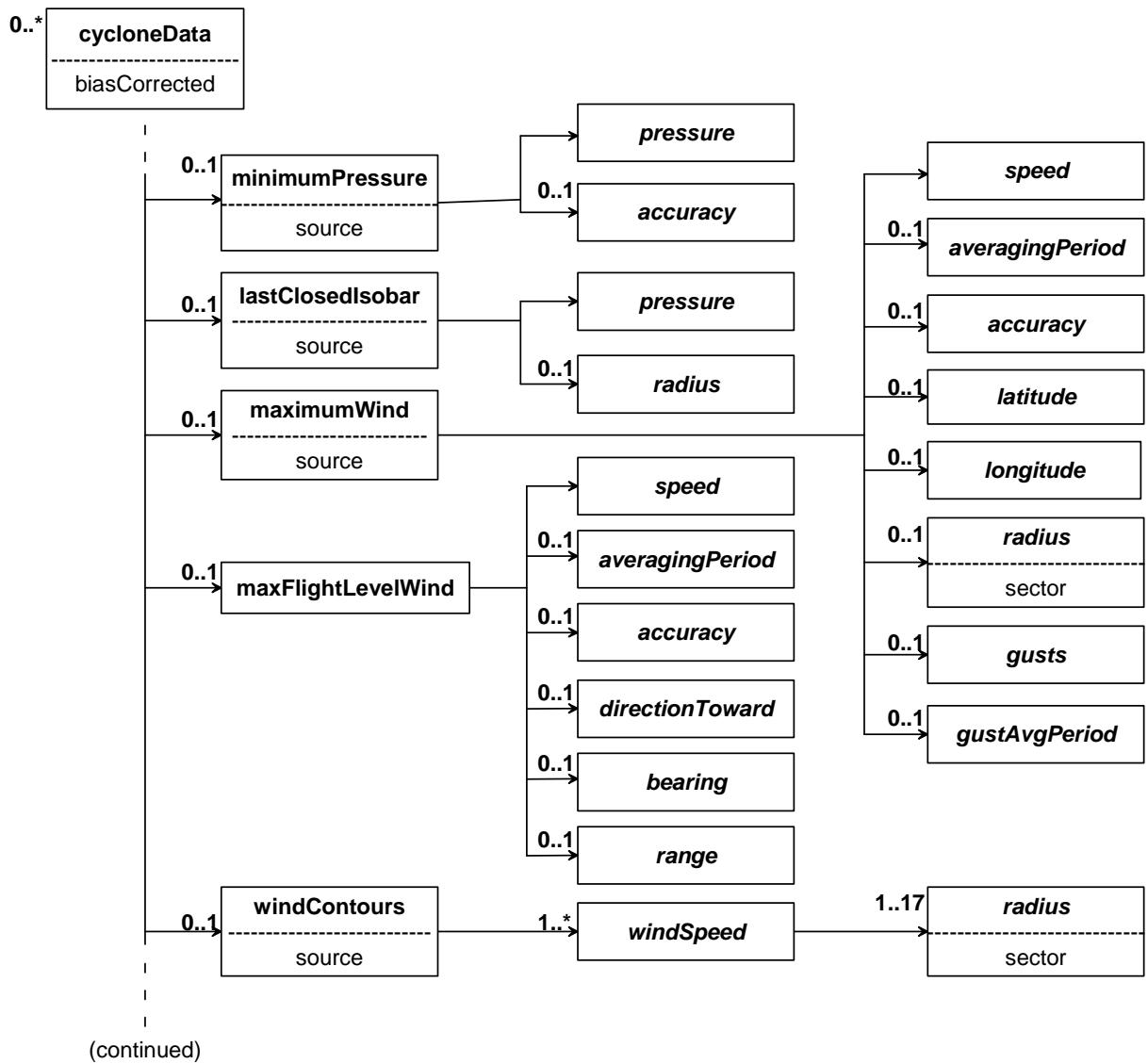

Data model for the cyclone data segment: pressure and winds. The level 1 elements (<minimumPressure>, <lastClosedIsobar>, etc.) may be given in any order.

Cyclone XML Specification

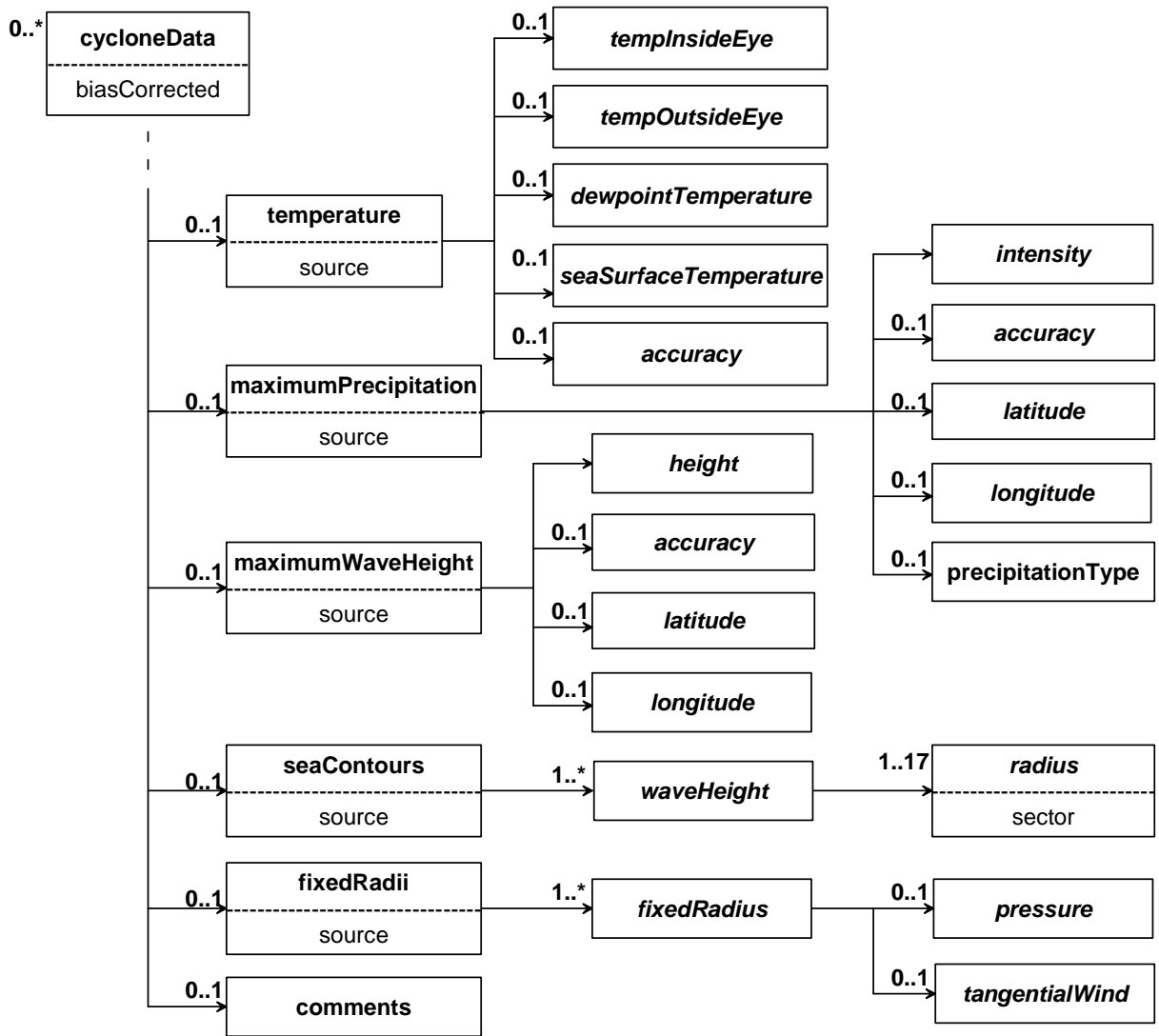

Data model for the cyclone data segment: temperature, precipitation, and seas. The level 1 elements (<temperature>, <maximumPrecipitation>, etc.) may be given in any order.

3 Description of CXML data elements

The following is a description of the CXML data elements that can be specified in CXML. CXML is structured with a root <cxml> tag and has the following syntax (after Fig. 1):

```
<cxml>
  <header>
    ...
    Header (metadata) tags
    ...
  </header>
  <data>
    ...
    Data tags
    ...
  </data>
</cxml>
```

The <header> ... </header> group must appear once at the top of the file. The <data> ... </data> group must appear at least once, and may be repeated multiple times in the case of ensemble forecasts.

The following is an example of a brief CXML instance:

```
<cxml>
  <header>
    <product>Cyclone Analysis</product>
    <generatingApplication>
      <applicationType>Manual hurricane analysis</applicationType>
    </generatingApplication>
    <productionCenter>NHC</productionCenter>
    <creationTime>2007-07-25T15:42:00</creationTime>
  </header>
  <data type="analysis">
    <disturbance ID="2007072518_134N_1102E">
      <fix>
        <validTime>2007-07-25T12:00:00Z</validTime>
        <latitude units="deg N">13.2</latitude>
        <longitude units="deg E">110.0</longitude>
        <cycloneData>
          <development>tropical cyclone</development>
          <minimumPressure units="hPa">979.8</minimumPressure>
          <maximumWind>
            <speed units="m/s">49.8</speed>
            <averagingPeriod units="min">10</averagingPeriod>
            <radius units="km">25.2</radius>
          </maximumWind>
        </cycloneData>
      </fix>
    </disturbance>
  </data>
</cxml>
```

Many more tags are available for describing cyclone metadata and data, as described in the remainder of this section.

This specification uses the following approach to describing elements:

Element and attribute names are all lower case. Where multiple word names are required element and attribute names use "camelCase" so as to improve readability (ex. <creationDate>). Attribute and element names generally avoid the use of abbreviations to enhance readability.

Within this document, child elements are nested in a sub-paragraph under their parents.

Attributes are also nested but do not have the angle brackets ("<>") and are italicized bold.

When an element or attribute is associated with a certain type, this is provided in braces ("{}"). The prefix "xs:" is used to indicate that this is a standard XML type. The prefix "cxml:" indicates that the type is defined for use in CXML. Further information on standard XML types is available at the W3Schools site <http://www.w3schools.com/schema/default.asp>.

The number of times an element occurs is indicated by a special symbol after its name:

| | |
|--------------------|---------|
| zero or more times | * |
| zero or one time | ? |
| one or more times | + |
| exactly one time | (blank) |

Special notes on CXML usage are printed in italics and marked with an arrow.

Many of the data elements have attributes giving the units and precision of the data. Preferred values for the units are given in Tables A1.1-A1.7 in Appendix 1.

The order of element descriptions in the paragraphs below is not significant. Any required ordering of elements is specified in the tree diagrams found in Section 2 and CXML schema found in Section 4.

3.1 Framework elements

3.1.1 **<cxml>**: The root element for CXML. It must contain the <header> element describing the metadata, followed by one or more <data> elements describing the data.

3.1.1.1. **<header>**: Contains the metadata for the CXML instance. See section 3.2 for elements found in the <head> element.

3.1.1.2. **<data> [+]**: Contains the data. For most types of analyses and forecasts this occurs only once, but for ensemble forecasts there will be one <data> element for each ensemble member. It is also possible to include both an analysis and a forecast if desired.

3.1.1.2.1. **<disturbance> [*]**: Data on a particular cyclone. See Section 3.3 for elements found in the <disturbance> element

3.1.1.2.2. ***type* {cxml:dataType}**: Type of data. This can have the following values:

| |
|------------------|
| <i>type</i> |
| analysis |
| forecast |
| ensembleForecast |

3.1.1.2.3. **member** {xs:nonNegativeInteger} [?]: Ensemble member number

3.1.1.2.4. **perturb** {cxml:perturbType} [?]: Perturbation type. This can have the following values:

| |
|----------------|
| perturb |
| control |
| positive |
| negative |
| simplex |
| other |

3.1.1.2.5. **origin** {xs:normalizedString} [?]: Source of the ensemble member. Normally this would be used only for multi-model ensembles.

3.2 Metadata elements

3.2.1. **<product>** {xs:string}: Name of the analysis or forecast product.

3.2.2. **<trackingDomain>** {xs:string} [?]: Description of the domain in which the cyclones were tracked. Latitude-longitude boundaries are encouraged.

3.2.3. **<generatingApplication>**: Information on the application that generated the analysis or forecast product

3.2.3.1. **<applicationType>** {xs:string}: Type of application, such as "manual analysis", "NWP forecast", etc.

3.2.3.2. **<model>** [*]: Information about the NWP model producing the analysis or forecast. This element can occur more than once if more than one model was used (e.g., multi-model ensemble)

3.2.3.2.1. **<name>** {xs:normalizedString}: Name of the NWP model

3.2.3.2.2. **<domain>** {xs:normalizedString}: Description of model domain (e.g., "global", latitude/longitude boundaries, etc.)

3.2.3.2.3. **<modelResolution>** {xs:normalizedString} [?]: Resolution at which model is run (e.g., "T799", "0.1 degrees", etc.)

3.2.3.2.4. **<dataResolution>** {cxml:anyNumber} [?]: Grid resolution of distributed data

3.2.3.2.4.1. **units** {xs:normalizedString}: Units of data resolution (refer to Table A1.1)

3.2.3.2.5. **<productionStatus>** {xs:string} [?]: Same as GRIB2 'productionStatusOfProcessedData'; can be either "prod" or "test".

3.2.3.3. **<ensemble>** [?]: Information about the ensemble prediction system

3.2.3.3.1. **<numMembers>** {xs:integer}: Number of members in the ensemble

3.2.3.3.2. **<perturbationMethod>** {xs:normalizedString}: Perturbation method used to generate the initial conditions

- 3.2.4. **<productionCenter>**: Name of the center that produced the analysis or forecast
 - 3.2.4.1. **<subCenter>** {xs:string} [?]: Name of sub-center
- 3.2.5. **<moreInfo>** {xs:anyURI} [?]: URL where more information on the production center can be obtained
- 3.2.6. **<moreMetadata>** {xs:anyURI} [?]: URL where more metadata on the forecast or analysis product can be obtained
- 3.2.7. **<baseTime>** {xs:dateTime} [?]: Base (initial) time of the forecast. The syntax is YYYY-MM-DDThh:mm:ss and the time coordinates are UTC.
- 3.2.8. **<creationTime>** {xs:dateTime}: Creation time of this product (UTC).
- 3.2.9. **<spatialReferenceSystem>** [?]: Information about the spatial reference system used to go between latitude/longitude and distance on the earth
 - 3.2.9.1. **<name>** {xs:normalizedString}: Name of spatial reference system (ex: "EPSG:4326")
 - 3.2.9.2. **<radius>** {cxml:anyNumber} [?]: Earth radius if spherical shape is assumed
 - 3.2.9.2.1.1. **units** {xs:normalizedString}: Units of radius (refer to Table A1.1)
- 3.2.10. **<missing>** {xs:normalizedString} [?]: String or numerical value used to represent missing data (ex: -999). Note that missing *numerical* data can also be represented by including xsi:nil="true" in the tag.

3.3 Disturbance data elements

- 3.3.1. **ID** {cxml:IDtype}: ID of the disturbance (cyclone). This reflects the date, time, and position of the first detection of the storm and takes the form of "YYYYMMDD_latx10NS_lonx10EW". For example, "2007072518_134N_1102E" is the ID for a storm detected at 18 UTC on 25 July 2007 at 13.4°N, 110.2°E. This same ID should be used in subsequent analyses and forecasts to facilitate tracking of the storm.
- 3.3.2. **<cycloneName>** {xs:normalizedString} [?]: Name of the storm (ex: "George")
- 3.3.3. **<cycloneNumber>** {xs:integer} [?]: Cyclone number for the season and basin
- 3.3.4. **<localID>** {xs:string} [?]: This element can be used to carry any locally used identification relevant for downstream applications
- 3.3.5. **<basin>** {xs:string} [?]: Ocean basin in which the cyclone exists. This can have any of the following values:

| basin (full name) | basin (abbreviation) |
|-----------------------|----------------------|
| Western North Pacific | WP |
| North Indian Ocean | IO |
| Southern Hemisphere | SH |
| Central North Pacific | CP |
| Eastern North Pacific | EP |
| North Atlantic | AL |

Cyclone XML Specification

3.3.6. **<objectiveTechnique>** {xs:string} [?]: Objective technique used to produce forecast or analysis

3.3.7. **<fix>** [+]: Position of a disturbance at a particular time

3.3.7.1. **hour** {cxml:anyNumber} [?]: Forecast hour corresponding to the fix

3.3.7.2. **source** {cxml:sourceType} [?]: Source of observations or other data used to derive fix. This can have one of the following values:

| <i>source</i> |
|------------------------|
| satellite |
| aircraft |
| dropsonde |
| radar |
| synoptic |
| Dvorak |
| outer closed isobar |
| poorly defined eye |
| over water observation |
| over land observation |
| model |
| other |

3.3.7.3. **<validTime>** {xs:dateTime}: Time corresponding to the fix (UTC).

3.3.7.4. **<latitude>** {cxml:anyNumber}: Latitude of the storm

3.3.7.4.1. **units** {xs:normalizedString}: Units of latitude (refer to Table A1.4)

3.3.7.4.2. **precision** {cxml:anyNumber} [?]: Precision of latitude value

3.3.7.5. **<longitude>** {cxml:anyNumber}: Longitude of the storm

3.3.7.5.1. **units** {xs:normalizedString}: Units of longitude (refer to Table A1.4)

3.3.7.5.2. **precision** {cxml:anyNumber} [?]: Precision of longitude value

3.3.7.6. **<accuracy>** {cxml:anyNumber} [?]: Accuracy of latitude/longitude fix

3.3.7.6.1. **units** {xs:normalizedString}: Units of latitude/longitude (refer to Table A1.4)

3.3.7.7. **<subRegion>** {xs:string} [?]: Sub-region of the basin where the cyclone is located, or continent in the case of extra-tropical cyclone tracks. This can have the following values:

| subRegion |
|--------------------|
| Arabian Sea |
| Bay of Bengal |
| Central Pacific |
| Eastern Pacific |
| South Pacific |
| South Indian Ocean |
| Western Pacific |
| North America |

| |
|---------------|
| South America |
| Europe |
| Asia |
| Australia |
| Africa |
| Antarctica |
| Arctic |

3.3.7.8. **<positionCodeNumber>** {xs:integer} [?]: Integer value between 1 and 6 describing how a satellite fix was derived.

| positionCodeNumber | fix determination |
|---------------------------|---|
| 1 | eye / geography |
| 2 | eye / ephemeris |
| 3 | well defined circulation center / geography |
| 4 | well defined circulation center / ephemeris |
| 5 | poorly defined circulation center / geography |
| 6 | poorly defined circulation center / ephemeris |

3.3.7.9. **<satelliteName>** {xs:normalizedString} [?]: Name of satellite from which satellite fix was derived.

3.3.7.10. **<satelliteSensor>** {xs:normalizedString} [?]: Name of satellite sensor from which satellite fix was derived.

3.3.7.11. **<fixSite>** {xs: normalizedString} [?]: Name of site or center where fix was determined

3.3.7.12. **<flightLevel>** {cxml:anyNumber} [?]: Flight level of aircraft used for aircraft fix

3.3.7.12.1. **units** {xs:normalizedString}: Units of altitude (refer to Table A1.1)

3.3.7.12.2. **precision** {cxml:anyNumber} [?]: Precision of flight level value

3.3.7.13. **<navAccuracy>** {cxml:anyNumber} [?]: Navigation accuracy of aircraft fix

3.3.7.13.1. **units** {xs:normalizedString}: Units of distance (refer to Table A1.1)

3.3.7.14. **<missionNumber>** {xs:integer} [?]: Mission number for aircraft fix

3.3.7.15. **<platform>** {xs:string} [?]: Platform for the radar fix. This can have the following values:

| |
|-----------------|
| platform |
| land |
| ship |
| aircraft |

3.3.7.16. **<RADOBcode>** {xs:normalizedString} [?]: RADOB code for radar fix

3.3.7.17. **<radarSitePosition>** [?]: Information on radar site used for radar fix

3.3.7.17.1. **<latitude>**: See 3.3.7.2

3.3.7.17.2. **<longitude>**: See 3.3.7.3

3.3.7.17.3. **<WMOidentifier>** {xs: normalizedString} [?]: WMO site ID

3.3.7.18. **<distanceToNearestData>** {cxml:anyNumber} [?]: Used in ATCF for synoptic fix

3.3.7.18.1. **units** {xs:normalizedString}: Units of distance (refer to Table A1.1)

3.3.7.19. **<cycloneData>** [*]: Physical data describing the cyclone. Normally there would be only one instance of <cycloneData>, but in the case of multiple eyes it may be desirable to include an instance of <cycloneData> for each eye. See section 3.4 for elements found in the <cycloneData> segment.

3.3.7.19.1. **biasCorrected** {xs:Boolean} [?]: Indicator for whether or not the NWP forecast has been bias corrected. Acceptable values are "true", "false", 1 (true), and 0 (false).

3.4 cycloneData elements

Note that all elements contained in <cycloneData> are optional and can be given in any order.

3.4.1. **<development>** {xs:string} [?]: Developmental phase of the cyclone. This can have any of the following values, taken from the Global Guide to Tropical Cyclone Forecasting (available online at http://www.bom.gov.au/bmrc/pubs/tcguide/ch1/ch1_3.htm):

| development | | |
|-------------------------|-------------------------------|------------------------|
| disturbance | tropical cyclone | subtropical depression |
| tropical disturbance | severe tropical cyclone | subtropical storm |
| depression | intense tropical cyclone | extratropical system |
| tropical depression | very intense tropical cyclone | inland |
| deep depression | typhoon | dissipating |
| tropical storm | super typhoon | low |
| moderate tropical storm | cyclonic disturbance | tropical wave |
| severe tropical storm | cyclonic storm | extrapolated |
| hurricane | severe cyclonic storm | unknown |

It is desirable to add extratropical cyclone phases in the future.

3.4.2. **<systemDepth>** {xs:string} [?]: Depth of cyclone. This can have the following values:

| systemDepth |
|-------------|
| deep |
| medium |
| shallow |
| unknown |

3.4.3. **<category>** {xs:integer} [?]: Integer storm category (1-6)

3.4.4. **<Dvorak>** [?]: Satellite-based Dvorak code for TC intensity (for more information see Veldon et al., *Bull. Amer. Meteor. Soc.*, September 2006)

3.4.4.1. **<dataTnumber>** {cxml:TnumberType} [?]: T-number based on structure of cloud. Syntax is of the form "typeX.X" where "type" is either T (tropical), ST (subtropical), or XT (extratropical transition) and X.X is a number between 0.0 and 8.0. An example is "T3.5".

3.4.4.2. **<modelExpectedTnumber>** {cxml:TnumberType} [?]: T-number based on trends in the imagery and a model of storm development. The syntax is as above.

Cyclone XML Specification

- 3.4.4.3. **<patternTnumber>** {cxml:TnumberType} [?]: T-number based on the observed cloud pattern. The syntax is as above.
- 3.4.4.4. **<finalTnumber>** {cxml:TnumberType}: T-number based on the best estimate from the three values above, subject to constraints. The syntax is as above.
- 3.4.4.5. **<ongoingChange>** {xs:string} [?]: Ongoing change. Can be either "PLUS" or "MINUS".
- 3.4.4.6. **<currentIntensity>** {cxml:TnumberType} [?]: T-number based on current intensity (usually the same as <finalTnumber> unless cyclone is decaying). The syntax is as above.
- 3.4.4.7. **<pastChange>** {xs:string}: Past change in the last <changePeriod> hours (see below). Syntax is of the form "changeX.X" where "change" is either D (developed), S (steady), or W (weakened) and X.X is the T-number change. An example is "W0.5".
- 3.4.4.8. **<changePeriod>** {cxml:anyNumber}: Period over which change was calculated.

- 3.4.4.8.1. **units** {xs:normalizedString}: Units of time (refer to Table A1.2)

- 3.4.5. **<spiralOverlay>** {cxml:anyNumber} [?]: Spiral overlay detected in radar fix (from ATCF).

- 3.4.5.1.1. **units** {xs:normalizedString}: Units of rotation (refer to Table A1.6)

- 3.4.6. **<eye>** [?]: Data describing the cyclone eye

- 3.4.6.1. **source** {cxml:sourceType} [?]: Source of observational data for describing eye (see 3.3.7.2)

- 3.4.6.2. **<shape>** {xs:string} [?]: Shape of the eye. Can have the following values:

| |
|--------------|
| shape |
| circular |
| elliptic |
| concentric |

- 3.4.6.3. **<orientation>** {cxml:anyNumber} [?]: If the eye shape is elliptic, this describes its orientation

- 3.4.6.3.1. **units** {xs:normalizedString}: Units of angle (refer to Table A1.6)

- 3.4.6.3.2. **precision** {cxml:anyNumber} [?]: Precision of orientation value

- 3.4.6.4. **<diameter>** {cxml:anyNumber} [?]: If the eye shape is elliptic, this describes its long axis.

- 3.4.6.4.1. **units** {xs:normalizedString}: Units of distance (refer to Table A1.1)

- 3.4.6.4.2. **precision** {cxml:anyNumber} [?]: Precision of diameter value

- 3.4.6.5. **<shortAxis>** {cxml:anyNumber} [?]: If the eye shape is elliptic, this describes its short axis, otherwise omit this element.

Cyclone XML Specification

- 3.4.6.5.1. **units** {xs:normalizedString}: Units of distance (refer to Table A1.1)
- 3.4.6.5.2. **precision** {cxml:anyNumber} [?]: Precision of short axis value
- 3.4.6.6. <**wallCloudThickness**> {cxml:anyNumber} [?]: Thickness of wall cloud
 - 3.4.6.6.1. **units** {xs:normalizedString}: Units of distance (refer to Table A1.1)
- 3.4.6.7. <**percentWallObserved**> {cxml:anyNumber} [?]: Percent of wall cloud observed in radar fix
- 3.4.7. <**stormMotion**> [?]: Data describing the storm's speed and direction
 - 3.4.7.1. **source** {cxml:sourceType} [?]: Source of observational data for describing storm motion (see 3.3.7.2)
 - 3.4.7.2. <**speed**> {cxml:anyNumber}: Speed of storm
 - 3.4.7.2.1. **units** {xs:normalizedString}: Units of speed (refer to Table A1.3)
 - 3.4.7.2.2. **precision** {cxml:anyNumber} [?]: Precision of speed value
 - 3.4.7.3. <**directionToward**> {cxml:anyNumber}: Direction storm is moving toward
 - 3.4.7.3.1. **units** {xs:normalizedString}: Units of angle (refer to Table A1.6)
 - 3.4.7.3.2. **precision** {cxml:anyNumber} [?]: Precision of direction value
 - 3.4.7.4. <**speedAccuracy**> {cxml:anyNumber} [?]: Accuracy of storm speed value
 - 3.4.7.4.1. **units** {xs:normalizedString}: Units of speed (refer to Table A1.3)
 - 3.4.7.5. <**directionAccuracy**> {cxml:anyNumber} [?]: Accuracy of storm direction value
 - 3.4.7.5.1. **units** {xs:normalizedString}: Units of angle (refer to Table A1.6)
- 3.4.8. <**cyclonePhase**> [?]: Data on cyclone phase (from Hart, *Mon. Wea. Rev.*, 1993)
 - 3.4.8.1. <**stormRelThkSymmetry**> {cxml:anyNumber}: Storm relative thickness symmetry
 - 3.4.8.1.1. **units** {xs:normalizedString}: Units of distance (refer to Table A1.1)
 - 3.4.8.2. <**thermalWindLower**> {cxml:anyNumber}: 900-600 hPa thermal wind
 - 3.4.8.2.1. **units** {xs:normalizedString}: Units of speed (refer to Table A1.3)
 - 3.4.8.3. <**thermalWindUpper**> {cxml:anyNumber}: 600-300 hPa thermal wind
 - 3.4.8.3.1. **units** {xs:normalizedString}: Units of speed (refer to Table A1.3)
- 3.4.9. <**minimumPressure**> [?]: Minimum sea level pressure
 - 3.4.9.1. **source** {cxml:sourceType} [?]: Source of data for estimating pressure (as in 3.3.7.2)
 - 3.4.9.2. <**pressure**> {cxml:anyNumber}: Pressure value
 - 3.4.9.1.1. **units** {xs:normalizedString}: Units of pressure (refer to Table A1.5)

Cyclone XML Specification

- 3.4.9.1.2. **precision** {cxml:anyNumber} [?]: Precision of pressure value
- 3.4.9.2. **<accuracy>** {cxml:anyNumber} [?]: Accuracy of pressure value
 - 3.4.9.2.1. **units** {xs:normalizedString}: Units of pressure (refer to Table A1.5)
- 3.4.10. **<lastClosedIsobar>** [?]: Data describing the pressure and radius of the last closed isobar.
 - 3.4.10.2. **source** {cxml:sourceType} [?]: Source of data for estimating value of last closed isobar (as in 3.3.7.2)
 - 3.4.10.1. **<pressure>** {cxml:anyNumber}: Pressure value (as in 3.4.9.1)
 - 3.4.10.2. **<radius>** {cxml:anyNumber} [?]: Radius of last closed isobar
 - 3.4.10.2.1. **units** {xs:normalizedString}: Units of distance (refer to Table A1.1)
- 3.4.11. **<maximumWind>** [?]: Data describing the storm's maximum sustained wind at the surface. These elements may be given in any order.
 - 3.4.11.1. **source** {cxml:sourceType} [?]: Observation source for estimating maximum sustained wind (as in 3.3.7.2)
 - 3.4.11.2. **<speed>** {cxml:anyNumber}: Speed of maximum sustained wind
 - 3.4.11.2.1. **units** {xs:normalizedString}: Units of speed (refer to Table A1.3)
 - 3.4.11.2.2. **precision** {cxml:anyNumber} [?]: Precision of speed value
 - 3.4.11.3. **<averagingPeriod>** {cxml:anyNumber} [?]: Averaging period for maximum wind speed
 - 3.4.11.3.1. **units** {xs:normalizedString}: Units of time (refer to Table A1.2)
 - 3.4.11.4. **<accuracy>** {cxml:anyNumber} [?]: Accuracy of maximum wind speed estimate
 - 3.4.11.4.1. **units** {xs:normalizedString}: Units of speed (refer to Table A1.3)
 - 3.4.11.5. **<latitude>** {cxml:anyNumber} [?]: As for 3.3.7.4
 - 3.4.11.6. **<longitude>** {cxml:anyNumber} [?]: As for 3.3.7.5
 - 3.4.11.7. **<radius>** {cxml:anyNumber} [?]: Radius of maximum wind speed
 - 3.4.11.7.1. **units** {xs:normalizedString}: Units of distance (refer to Table A1.1)
 - 3.4.11.7.2. **sector** {cxml:sectorType} [?]: Sector in which maximum wind is located (see 3.4.13.1.2.2)
 - 3.4.11.8. **<bearing>** {cxml:anyNumber} [?]: Bearing of maximum wind
 - 3.4.11.8.1. **units** {xs:normalizedString}: Units of angle (refer to Table A1.6)
 - 3.4.11.8.2. **precision** {cxml:anyNumber} [?]: Precision of bearing value
 - 3.4.11.9. **<range>** {cxml:anyNumber} [?]: Range of maximum wind

Cyclone XML Specification

- 3.4.11.9.1. **units** {xs:normalizedString}: Units of distance (refer to Table A1.1)
- 3.4.11.9.2. **precision** {cxml:anyNumber} [?]: Precision of range value
- 3.4.11.10. **<gusts>** {cxml:anyNumber} [?]: Maximum gusts near the surface
 - 3.4.11.10.1. **units** {xs:normalizedString}: Units of speed (refer to Table A1.3)
 - 3.4.11.10.2. **precision** {cxml:anyNumber} [?]: Precision of gust value
- 3.4.11.11. **<gustAvgPeriod>** {cxml:anyNumber} [?]: Averaging period for gusts
 - 3.4.11.11.1. **units** {xs:normalizedString}: Units of time (refer to Table A1.2)
- 3.4.12. **<maxFlightLevelWind>** [?]: Data describing the storm's maximum sustained wind speed at flight level. These elements may be given in any order.
 - 3.4.12.1. **<speed>** {cxml:anyNumber}: As for 3.4.11.2
 - 3.4.12.2. **<averagingPeriod>** {cxml:anyNumber} [?]: As for 3.4.11.3
 - 3.4.12.3. **<accuracy>** {cxml:anyNumber} [?]: As for 3.4.11.4
 - 3.4.12.4. **<directionToward>** {cxml:anyNumber} [?]: Direction of maximum wind
 - 3.4.12.4.1. **units** {xs:normalizedString}: Units of angle (refer to Table A1.6)
 - 3.4.12.5. **<bearing>** {cxml:anyNumber} [?]: As for 3.4.11.8
 - 3.4.12.6. **<range>** {cxml:anyNumber} [?]: As for 3.4.11.9
- 3.4.13. **<windContours>** [?]: Data describing the structure of the surface wind field
 - 3.4.13.1. **source** {cxml:sourceType} [?]: Source of observational data for estimating wind contours (as in 3.3.7.2)
 - 3.4.13.2. **<windSpeed>** {cxml:anyNumber} [+]: Wind speed threshold value
 - 3.4.13.2.1. **units** {xs:normalizedString}: Units of speed (refer to Table A1.3)
 - 3.4.13.2.2. **<radius>** {cxml:anyNumber} [+]: Radius where wind exceeds the given threshold
 - 3.4.13.2.2.1. **units** {xs:normalizedString}: Units of distance (refer to Table A1.1)
 - 3.4.13.2.2.2. **sector** {cxml:sectorType} [?]: Sector for which this radius is defined. Sectors may take the following values:

| sector (full name) | sector (abbreviation) |
|---------------------------|------------------------------|
| full circle | AAA |
| north semicircle | NNS |
| northeast semicircle | NES |
| east semicircle | EES |
| southeast semicircle | SES |
| south semicircle | SSS |
| southwest semicircle | SWS |

Cyclone XML Specification

| | |
|----------------------|-----|
| west semicircle | WWS |
| northwest semicircle | NWS |
| north quadrant | NNQ |
| northeast quadrant | NEQ |
| east quadrant | EEQ |
| southeast quadrant | SEQ |
| south quadrant | SSQ |
| southwest quadrant | SWQ |
| west quadrant | WWQ |
| northwest quadrant | NWQ |

3.4.14. **<temperature>** [?]: Data on temperatures in the storm and nearby environment. These are normally estimated from aircraft fixes but may be extracted from model output.

3.4.14.1. **source** {xml:sourceType} [?]: Source of observational data for describing storm's temperature (as in 3.3.7.2)

3.4.14.2. **<accuracy>** {xml:anyNumber} [?]: Accuracy of temperature estimates

3.4.14.2.1. **units** {xs:normalizedString}: Units of temperature (refer to Table A1.8)

3.4.14.3. **<tempOutsideEye>** {xml:anyNumber} [?]: Temperature outside of eye.

3.4.14.3.1. **units** {xs:normalizedString}: Units of temperature (refer to Table A1.8)

3.4.14.4. **<tempInsideEye>** {xml:anyNumber} [?]: Temperature inside eye.

3.4.14.4.1. **units** {xs:normalizedString}: Units of temperature (refer to Table A1.8)

3.4.14.5. **<dewpointTemperature>** {xml:anyNumber} [?]: Dewpoint temperature in the storm environment

3.4.14.5.1. **units** {xs:normalizedString}: Units of temperature (refer to Table A1.8)

3.4.14.6. **<seaSurfaceTemperature>** {xml:anyNumber} [?]: Sea surface temperature.

3.4.14.6.1. **units** {xs:normalizedString}: Units of temperature (refer to Table A1.8)

3.4.15. **<maximumPrecipitation>** [?]: Estimated maximum precipitation at surface

3.4.15.1. **source** {xml:sourceType} [?]: Source of observational data for estimating precipitation (as in 3.3.7.2)

3.4.15.2. **<intensity>** {xml:anyNumber}: Intensity of maximum precipitation

3.4.15.2.1. **units** {xs:normalizedString}: Units of precipitation rate (refer to Table A1.7)

3.4.15.2.2. **precision** {xml:anyNumber} [?]: Precision of precipitation intensity

3.4.15.3. **<accuracy>** {xml:anyNumber} [?]: Accuracy of precipitation intensity

3.4.15.3.1. **units** {xs:normalizedString}: Units of precipitation rate (refer to Table A1.7)

3.4.15.4. **<latitude>** {xml:anyNumber} [?]: As for 3.3.7.4

3.4.15.5. **<longitude>** {xml:anyNumber} [?]: As for 3.3.7.5

Cyclone XML Specification

3.4.15.6. **<precipitationType>** {xs:string} [?]: Dominant precipitation type. If neither "rain" nor "snow" then use "mixed". Can have values of:

| precipitationType |
|--------------------------|
| rain |
| snow |
| mixed |

3.4.16. **<maximumWaveHeight>** [?]: Maximum wave height

3.4.16.1. **source** {cxml:sourceType} [?]: Source of observational data for estimating maximum wave height (as in 3.3.7.2)

3.4.16.2. **<height>** {cxml:anyNumber}: Maximum wave height value

3.4.16.2.1. **units** {xs:normalizedString}: Units of distance (refer to Table A1.1)

3.4.16.2.2. **precision** {cxml:anyNumber} [?]: Precision of wave height

3.4.16.3. **<accuracy>** {cxml:anyNumber} [?]: Accuracy of wave height estimate

3.4.16.3.1. **units** {xs:normalizedString}: Units of distance (refer to Table A1.1)

3.4.16.4. **<latitude>** {cxml:anyNumber} [?]: As for 3.3.7.4

3.4.16.5. **<longitude>** {cxml:anyNumber} [?]: As for 3.3.7.5

3.4.17. **<seaContours>** [?]: Data describing the structure of the wave height field

3.4.17.1. **source** {cxml:sourceType} [?]: Source of observational data for estimating wave height contours (as in 3.3.7.2)

3.4.17.2. **<waveHeight>** {cxml:anyNumber} [+]: Wave height threshold value

3.4.17.2.1. **units** {xs:normalizedString}: Units of distance (refer to Table A1.1)

3.4.17.2.2. **<radius>** {cxml:anyNumber} [+]: Radius where wave height exceeds the given threshold

3.4.17.2.2.1. **units** {xs:normalizedString}: Units of distance (refer to Table A1.1)

3.4.17.2.2.2. **sector** {cxml:sectorType} [?]: Sector for which this radius is defined. See 3.4.13.1.2.2.

3.4.18. **<fixedRadii>** [?]: Data given at fixed radii from storm center

3.4.18.1. **source** {cxml:sourceType} [?]: Source of data for estimating fixed radii (as in 3.3.7.2)

3.4.18.2. **<fixedRadius>** {cxml:anyNumber} [+]: Radius value

3.4.18.2.1. **units** {xs:normalizedString}: Units of distance (refer to Table A1.1)

3.4.18.2.2. **<pressure>** {cxml:anyNumber} [?]: As for 3.4.9.1

3.4.18.2.3. **<tangentialWind>** {cxml:anyNumber} [?]: Tangential wind speed

3.4.18.2.3.1. **units** {xs:normalizedString}: Units of speed (refer to Table A1.3)

Cyclone XML Specification

3.4.18.2.3.2. ***precision*** {cxml:anyNumber} [?]: Precision of wind speed value

3.4.19. **<comments>** {xs:string} [?]: Any comments can be inserted here!

4 Schema for CXML v.1.0

The schema can be viewed on the CXML web page

<http://www.bom.gov.au/bmrc/projects/THORPEX/CXML/index.html>.

```
<?xml version="1.0" encoding="UTF-8"?>
<xs:schema xmlns:xs="http://www.w3.org/2001/XMLSchema">

  <xs:element name="cxml">
    <xs:complexType>
      <xs:sequence>
        <xs:element ref="header"/>
        <xs:element ref="data" minOccurs="1" maxOccurs="unbounded"/>
      </xs:sequence>
    </xs:complexType>
  </xs:element>

  <xs:element name="header">
    <xs:annotation>
      <xs:documentation>Metadata about production center and base time
        of the analysis and/or forecast</xs:documentation>
    </xs:annotation>
    <xs:complexType>
      <xs:all>
        <xs:element ref="product"/>
        <xs:element ref="generatingApplication"/>
        <xs:element ref="productionCenter"/>
        <xs:element ref="moreInfo" minOccurs="0" maxOccurs="1"/>
        <xs:element ref="moreMetadata" minOccurs="0" maxOccurs="1"/>
        <xs:element ref="baseTime" minOccurs="0" maxOccurs="1"/>
        <xs:element ref="creationTime"/>
        <xs:element ref="spatialReferenceSystem" minOccurs="0" maxOccurs="1"/>
        <xs:element ref="missing" minOccurs="0" maxOccurs="1"/>
      </xs:all>
    </xs:complexType>
  </xs:element>

  <xs:element name="product" type="xs:string"/>
  <xs:element name="trackingDomain" type="xs:string"/>

  <xs:element name="generatingApplication">
    <xs:complexType>
      <xs:sequence>
        <xs:element ref="applicationType"/>
        <xs:element ref="model" minOccurs="0" maxOccurs="unbounded"/>
        <xs:element ref="ensemble" minOccurs="0" maxOccurs="1"/>
      </xs:sequence>
    </xs:complexType>
  </xs:element>

  <xs:element name="applicationType" type="xs:string"/>

  <xs:element name="model">
    <xs:annotation>
```

Cyclone XML Specification

```
<xs:documentation>Information about the NWP model producing the analysis or
forecast</xs:documentation>
</xs:annotation>
<xs:complexType>
  <xs:sequence>
    <xs:element ref="name"/>
    <xs:element ref="domain"/>
    <xs:element ref="modelResolution" minOccurs="0" maxOccurs="1"/>
    <xs:element ref="dataResolution" minOccurs="0" maxOccurs="1"/>
    <xs:element ref="productionStatus" minOccurs="0" maxOccurs="1"/>
  </xs:sequence>
</xs:complexType>
</xs:element>

<xs:element name="name" type="xs:normalizedString"/>
<xs:element name="domain" type="xs:normalizedString"/>

<xs:element name="modelResolution" type="xs:normalizedString">
  <xs:annotation>
    <xs:documentation>Resolution at which model is run</xs:documentation>
  </xs:annotation>
</xs:element>

<xs:element name="dataResolution">
  <xs:annotation>
    <xs:documentation>Grid resolution of distributed data</xs:documentation>
  </xs:annotation>
  <xs:complexType>
    <xs:simpleContent>
      <xs:extension base="anyNumber">
        <xs:attribute name="units" use="required" type="xs:normalizedString"/>
      </xs:extension>
    </xs:simpleContent>
  </xs:complexType>
</xs:element>

<xs:element name="productionStatus">
  <xs:annotation>
    <xs:documentation>Same as GRIB2
'productionStatusOfProcessedData'</xs:documentation>
  </xs:annotation>
  <xs:simpleType>
    <xs:restriction base="xs:string">
      <xs:enumeration value="prod"/>
      <xs:enumeration value="test"/>
    </xs:restriction>
  </xs:simpleType>
</xs:element>

<xs:element name="ensemble">
  <xs:annotation>
    <xs:documentation>Information about the ensemble prediction
system</xs:documentation>
  </xs:annotation>
  <xs:complexType>
    <xs:sequence>
      <xs:element ref="numMembers"/>
      <xs:element ref="perturbationMethod"/>
    </xs:sequence>
  </xs:complexType>
</xs:element>
```

Cyclone XML Specification

```
</xs:sequence>
</xs:complexType>
</xs:element>

<xs:element name="numMembers" type="xs:integer"/>
<xs:element name="perturbationMethod" type="xs:normalizedString"/>

<xs:element name="productionCenter">
  <xs:complexType mixed="true">
    <xs:sequence>
      <xs:element ref="subCenter" minOccurs="0" maxOccurs="1"/>
    </xs:sequence>
  </xs:complexType>
</xs:element>

<xs:element name="subCenter" type="xs:string"/>
<xs:element name="moreInfo" type="xs:anyURI"/>
<xs:element name="moreMetadata" type="xs:anyURI"/>
<xs:element name="baseTime" type="xs:dateTime"/>
<xs:element name="creationTime" type="xs:dateTime"/>

<xs:element name="spatialReferenceSystem">
  <xs:annotation>
    <xs:documentation>Information about the spatial reference system used
      to go between latitude/longitude and distance on the earth</xs:documentation>
  </xs:annotation>
  <xs:complexType>
    <xs:sequence>
      <xs:element ref="name"/>
      <xs:element ref="radius" minOccurs="0" maxOccurs="1"/>
    </xs:sequence>
  </xs:complexType>
</xs:element>

<xs:element name="missing" type="xs:normalizedString">
  <xs:annotation>
    <xs:documentation>Optional string or numerical value used to represent
      missing data (ex: -999).
      Note that missing numerical data can also be represented by including
      xsi:nil="true" in the tag.</xs:documentation>
  </xs:annotation>
</xs:element>

<xs:element name="data">
  <xs:annotation>
    <xs:documentation>Data content of the analysis or forecast.
      The type can be 'analysis', 'forecast' or 'ensembleForecast'
      Normally a file would have only one type of data
      but in some cases it may be desirable to have both an analysis and a
      forecast.
      Several disturbances (cyclones) can be included in a single data
      element.</xs:documentation>
  </xs:annotation>
  <xs:complexType>
    <xs:sequence>
      <xs:element ref="disturbance" minOccurs="0" maxOccurs="unbounded"/>
    </xs:sequence>
    <xs:attribute name="type" use="required" type="dataType"/>
  </xs:complexType>
</xs:element>
```

Cyclone XML Specification

```
<xs:attribute name="member" use="optional" type="xs:nonNegativeInteger"/>
<xs:attribute name="perturb" use="optional" type="perturbType"/>
<xs:attribute name="origin" use="optional" type="xs:normalizedString"/>
</xs:complexType>
</xs:element>

<xs:element name="disturbance">
  <xs:annotation>
    <xs:documentation>Data on a particular storm (disturbance)</xs:documentation>
  </xs:annotation>
  <xs:complexType>
    <xs:sequence>
      <xs:element ref="cycloneName" minOccurs="0" maxOccurs="1"/>
      <xs:element ref="cycloneNumber" minOccurs="0" maxOccurs="1"/>
      <xs:element ref="localID" minOccurs="0" maxOccurs="1"/>
      <xs:element ref="basin" minOccurs="0" maxOccurs="1"/>
      <xs:element ref="objectiveTechnique" minOccurs="0" maxOccurs="1"/>
      <xs:element ref="fix" minOccurs="1" maxOccurs="unbounded"/>
    </xs:sequence>
    <xs:attribute name="ID" use="required" type="IDtype"/>
  </xs:complexType>
</xs:element>

<xs:element name="cycloneName" type="xs:normalizedString"/>
<!-- ATCF - annual cyclone number -->
<xs:element name="cycloneNumber" type="xs:integer"/>

<xs:element name="localID" type="xs:string">
  <xs:annotation>
    <xs:documentation>Specified by production center or generating application
      for its own use</xs:documentation>
  </xs:annotation>
</xs:element>

<xs:element name="basin">
  <xs:annotation>
    <xs:documentation>Basin in which the storm is located at analysis time.
      Either 2-letter abbreviation or full words are acceptable.</xs:documentation>
  </xs:annotation>
  <xs:simpleType>
    <xs:restriction base="xs:string">
      <xs:enumeration value="WP"/>
      <xs:enumeration value="Western North Pacific"/>
      <xs:enumeration value="IO"/>
      <xs:enumeration value="North Indian Ocean"/>
      <xs:enumeration value="SH"/>
      <xs:enumeration value="Southern Hemisphere"/>
      <xs:enumeration value="CP"/>
      <xs:enumeration value="Central North Pacific"/>
      <xs:enumeration value="EP"/>
      <xs:enumeration value="Eastern North Pacific"/>
      <xs:enumeration value="AL"/>
      <xs:enumeration value="North Atlantic"/>
    </xs:restriction>
  </xs:simpleType>
</xs:element>

<xs:element name="objectiveTechnique" type="xs:string">
```

Cyclone XML Specification

```
<xs:annotation>
  <xs:documentation>Objective technique used to produce forecast or
analysis</xs:documentation>
</xs:annotation>
</xs:element>

<xs:element name="fix">
  <xs:annotation>
    <xs:documentation>Position of a disturbance at a particular
time</xs:documentation>
  </xs:annotation>
  <xs:complexType>
    <xs:sequence>
      <xs:element ref="validTime"/>
      <xs:element ref="latitude"/>
      <xs:element ref="longitude"/>
      <xs:element ref="accuracy" minOccurs="0" maxOccurs="1"/>
      <xs:element ref="subRegion" minOccurs="0" maxOccurs="1"/>
      <xs:element ref="positionCodeNumber" minOccurs="0" maxOccurs="1"/>
      <xs:element ref="satelliteName" minOccurs="0" maxOccurs="1"/>
      <xs:element ref="satelliteSensor" minOccurs="0" maxOccurs="1"/>
      <xs:element ref="fixSite" minOccurs="0" maxOccurs="1"/>
      <xs:element ref="flightLevel" minOccurs="0" maxOccurs="1"/>
      <xs:element ref="navAccuracy" minOccurs="0" maxOccurs="1"/>
      <xs:element ref="missionNumber" minOccurs="0" maxOccurs="1"/>
      <xs:element ref="platform" minOccurs="0" maxOccurs="1"/>
      <xs:element ref="RADOBcode" minOccurs="0" maxOccurs="1"/>
      <xs:element ref="radarSitePosition" minOccurs="0" maxOccurs="1"/>
      <xs:element ref="distanceToNearestData" minOccurs="0" maxOccurs="1"/>
      <xs:element ref="cycloneData" minOccurs="0" maxOccurs="unbounded"/>
    </xs:sequence>
    <xs:attribute name="hour" use="optional" type="anyNumber"/>
    <xs:attribute name="source" use="optional" type="sourceType"/>
  </xs:complexType>
</xs:element>

<xs:element name="validTime" type="xs:dateTime"/>

<xs:element name="latitude">
  <xs:complexType>
    <xs:simpleContent>
      <xs:extension base="anyNumber">
        <xs:attribute name="units" use="required" type="xs:normalizedString"/>
        <xs:attribute name="precision" use="optional" type="anyNumber"/>
      </xs:extension>
    </xs:simpleContent>
  </xs:complexType>
</xs:element>

<xs:element name="longitude">
  <xs:complexType>
    <xs:simpleContent>
      <xs:extension base="anyNumber">
        <xs:attribute name="units" use="required" type="xs:normalizedString"/>
        <xs:attribute name="precision" use="optional" type="anyNumber"/>
      </xs:extension>
    </xs:simpleContent>
  </xs:complexType>
</xs:element>
```

Cyclone XML Specification

```
</xs:element>

<xs:element name="subRegion" nillable="true">
  <xs:annotation>
    <xs:documentation>Subregion within the basin.</xs:documentation>
  </xs:annotation>
  <xs:simpleType>
    <xs:restriction base="xs:string">
      <xs:enumeration value="Arabian Sea"/>
      <xs:enumeration value="Bay of Bengal"/>
      <xs:enumeration value="Central Pacific"/>
      <xs:enumeration value="Eastern Pacific"/>
      <xs:enumeration value="Atlantic"/>
      <xs:enumeration value="South Pacific"/>
      <xs:enumeration value="South Indian Ocean"/>
      <xs:enumeration value="Western Pacific"/>
      <xs:enumeration value="North America"/>
      <xs:enumeration value="South America"/>
      <xs:enumeration value="Europe"/>
      <xs:enumeration value="Asia"/>
      <xs:enumeration value="Australia"/>
      <xs:enumeration value="Africa"/>
      <xs:enumeration value="Antarctica"/>
      <xs:enumeration value="Arctic"/>
    </xs:restriction>
  </xs:simpleType>
</xs:element>

<xs:element name="positionCodeNumber">
  <xs:annotation>
    <xs:documentation>Used for satellite fixes. 1=eye/geography, 2=eye/ephemeris,
      3=well defined circ. center/geography, 4=well defined circ. center/ephemeris,
      5=poorly defined circ. center/geography, 6=poorly defined circ.
center/ephemeris</xs:documentation>
  </xs:annotation>
  <xs:simpleType>
    <xs:restriction base="xs:integer">
      <xs:minInclusive value="1"/>
      <xs:maxInclusive value="6"/>
    </xs:restriction>
  </xs:simpleType>
</xs:element>

<xs:element name="satelliteName" type="xs:normalizedString"/>
<xs:element name="satelliteSensor" type="xs:normalizedString"/>

<xs:element name="fixSite" type="xs:normalizedString">
  <xs:annotation>
    <xs:documentation>Site or center where fix was determined </xs:documentation>
  </xs:annotation>
</xs:element>

<xs:element name="flightLevel" nillable="true">
  <xs:annotation>
    <xs:documentation>Used for aircraft fixes</xs:documentation>
  </xs:annotation>
  <xs:complexType>
    <xs:simpleContent>
```

Cyclone XML Specification

```
<xs:extension base="anyNumber">
  <xs:attribute name="units" use="required" type="xs:normalizedString"/>
  <xs:attribute name="precision" use="optional" type="anyNumber"/>
</xs:extension>
</xs:simpleContent>
</xs:complexType>
</xs:element>

<xs:element name="navAccuracy" nillable="true">
  <xs:annotation>
    <xs:documentation>Navigational accuracy</xs:documentation>
  </xs:annotation>
  <xs:complexType>
    <xs:simpleContent>
      <xs:extension base="anyNumber">
        <xs:attribute name="units" use="required" type="xs:normalizedString"/>
      </xs:extension>
    </xs:simpleContent>
  </xs:complexType>
</xs:element>

<xs:element name="missionNumber" type="xs:integer" nillable="true"/>

<xs:element name="platform" nillable="true">
  <xs:annotation>
    <xs:documentation>Platform for the radar observations</xs:documentation>
  </xs:annotation>
  <xs:simpleType>
    <xs:restriction base="xs:string">
      <xs:enumeration value="land"/>
      <xs:enumeration value="ship"/>
      <xs:enumeration value="aircraft"/>
    </xs:restriction>
  </xs:simpleType>
</xs:element>

<xs:element name="RADOBcode" type="xs:normalizedString" nillable="true"/>

<xs:element name="radarSitePosition">
  <xs:complexType>
    <xs:all>
      <xs:element ref="latitude"/>
      <xs:element ref="longitude"/>
      <xs:element ref="WMOidentifier" minOccurs="0" maxOccurs="1"/>
    </xs:all>
  </xs:complexType>
</xs:element>

<xs:element name="WMOidentifier" type="xs:normalizedString" nillable="true"/>

<xs:element name="distanceToNearestData" nillable="true">
  <xs:annotation>
    <xs:documentation>Used in ATCF for synoptic fix</xs:documentation>
  </xs:annotation>
  <xs:complexType>
    <xs:simpleContent>
      <xs:extension base="anyNumber">
        <xs:attribute name="units" use="required" type="xs:normalizedString"/>
      </xs:extension>
    </xs:simpleContent>
  </xs:complexType>
</xs:element>
```

Cyclone XML Specification

```

    </xs:extension>
  </xs:simpleContent>
</xs:complexType>
</xs:element>

<xs:element name="cycloneData">
  <xs:annotation>
    <xs:documentation>Data describing the storm's development and
status</xs:documentation>
  </xs:annotation>
  <xs:complexType>
    <xs:all>
      <xs:element ref="development" minOccurs="0" maxOccurs="1"/>
      <xs:element ref="systemDepth" minOccurs="0" maxOccurs="1"/>
      <xs:element ref="category" minOccurs="0" maxOccurs="1"/>
      <xs:element ref="Dvorak" minOccurs="0" maxOccurs="1"/>
      <xs:element ref="spiralOverlay" minOccurs="0" maxOccurs="1"/>
      <xs:element ref="eye" minOccurs="0" maxOccurs="1"/>
      <xs:element ref="stormMotion" minOccurs="0" maxOccurs="1"/>
      <xs:element ref="cyclonePhase" minOccurs="0" maxOccurs="1"/>
      <xs:element ref="minimumPressure" minOccurs="0" maxOccurs="1"/>
      <xs:element ref="lastClosedIsobar" minOccurs="0" maxOccurs="1"/>
      <xs:element ref="maximumWind" minOccurs="0" maxOccurs="1"/>
      <xs:element ref="maxFlightLevelWind" minOccurs="0" maxOccurs="1"/>
      <xs:element ref="windContours" minOccurs="0" maxOccurs="1"/>
      <xs:element ref="temperature" minOccurs="0" maxOccurs="1"/>
      <xs:element ref="maximumPrecipitation" minOccurs="0" maxOccurs="1"/>
      <xs:element ref="maximumWaveHeight" minOccurs="0" maxOccurs="1"/>
      <xs:element ref="seaContours" minOccurs="0" maxOccurs="1"/>
      <xs:element ref="fixedRadii" minOccurs="0" maxOccurs="1"/>
      <xs:element ref="comments" minOccurs="0" maxOccurs="1"/>
    </xs:all>
    <xs:attribute name="biasCorrected" use="optional" type="xs:boolean"/>
  </xs:complexType>
</xs:element>

<xs:element name="development" nillable="true">
  <xs:annotation>
    <xs:documentation>Development status of a disturbance</xs:documentation>
  </xs:annotation>
  <xs:simpleType>
    <xs:restriction base="xs:string">
      <xs:enumeration value="disturbance"/>
      <xs:enumeration value="tropical disturbance"/>
      <xs:enumeration value="depression"/>
      <xs:enumeration value="tropical depression"/>
      <xs:enumeration value="deep depression"/>
      <xs:enumeration value="tropical storm"/>
      <xs:enumeration value="moderate tropical storm"/>
      <xs:enumeration value="severe tropical storm"/>
      <xs:enumeration value="tropical cyclone"/>
      <xs:enumeration value="severe tropical cyclone"/>
      <xs:enumeration value="intense tropical cyclone"/>
      <xs:enumeration value="very intense tropical cyclone"/>
      <xs:enumeration value="hurricane"/>
      <xs:enumeration value="typhoon"/>
      <xs:enumeration value="super typhoon"/>
      <xs:enumeration value="cyclonic disturbance"/>
    </xs:restriction>
  </xs:simpleType>
</xs:element>

```

Cyclone XML Specification

```
<xs:enumeration value="cyclonic storm"/>
<xs:enumeration value="severe cyclonic storm"/>
<xs:enumeration value="subtropical depression"/>
<xs:enumeration value="subtropical storm"/>
<xs:enumeration value="extratropical system"/>
<xs:enumeration value="inland"/>
<xs:enumeration value="dissipating"/>
<xs:enumeration value="low"/>
<xs:enumeration value="tropical wave"/>
<xs:enumeration value="extrapolated"/>
<xs:enumeration value="unknown"/>
</xs:restriction>
</xs:simpleType>
</xs:element>

<xs:element name="systemDepth" nillable="true">
  <xs:annotation>
    <xs:documentation>Storm depth</xs:documentation>
  </xs:annotation>
  <xs:simpleType>
    <xs:restriction base="xs:string">
      <xs:enumeration value="deep"/>
      <xs:enumeration value="medium"/>
      <xs:enumeration value="shallow"/>
      <xs:enumeration value="unknown"/>
    </xs:restriction>
  </xs:simpleType>
</xs:element>

<xs:element name="category" nillable="true">
  <xs:annotation>
    <xs:documentation>Storm category (1-6)</xs:documentation>
  </xs:annotation>
  <xs:simpleType>
    <xs:restriction base="xs:integer">
      <xs:minInclusive value="1"/>
      <xs:maxInclusive value="6"/>
    </xs:restriction>
  </xs:simpleType>
</xs:element>

<xs:element name="Dvorak">
  <xs:annotation>
    <xs:documentation>Satellite-based Dvorak code for TC
intensity</xs:documentation>
  </xs:annotation>
  <xs:complexType>
    <xs:all>
      <xs:element ref="dataTnumber" minOccurs="0" maxOccurs="1"/>
      <xs:element ref="modelExpectedTnumber" minOccurs="0" maxOccurs="1"/>
      <xs:element ref="patternTnumber" minOccurs="0" maxOccurs="1"/>
      <xs:element ref="finalTnumber"/>
      <xs:element ref="ongoingChange" minOccurs="0" maxOccurs="1"/>
      <xs:element ref="currentIntensity"/>
      <xs:element ref="pastChange"/>
      <xs:element ref="changePeriod"/>
    </xs:all>
  </xs:complexType>

```

Cyclone XML Specification

```
</xs:element>

<xs:element name="dataTnumber" type="TnumberType" />
<xs:element name="modelExpectedTnumber" type="TnumberType" />
<xs:element name="patternTnumber" type="TnumberType" />
<xs:element name="finalTnumber" type="TnumberType" />
<xs:element name="currentIntensity" type="TnumberType" nillable="true"/>

<xs:element name="pastChange">
  <xs:simpleType>
    <xs:restriction base="xs:string">
      <xs:pattern value="[D|S|W][0-8].[0-7]"/>
    </xs:restriction>
  </xs:simpleType>
</xs:element>

<xs:element name="ongoingChange">
  <xs:simpleType>
    <xs:restriction base="xs:string">
      <xs:pattern value="(MINUS|PLUS)"/>
    </xs:restriction>
  </xs:simpleType>
</xs:element>

<xs:element name="changePeriod" nillable="true">
  <xs:complexType>
    <xs:simpleContent>
      <xs:extension base="anyNumber">
        <xs:attribute name="units" use="required" type="xs:normalizedString"/>
      </xs:extension>
    </xs:simpleContent>
  </xs:complexType>
</xs:element>

<xs:element name="maximumWind">
  <xs:annotation>
    <xs:documentation>Data describing the storm's maximum sustained wind
speed</xs:documentation>
  </xs:annotation>
  <xs:complexType>
    <xs:all>
      <xs:element ref="speed"/>
      <xs:element ref="averagingPeriod" minOccurs="0" maxOccurs="1"/>
      <xs:element ref="latitude" minOccurs="0" maxOccurs="1"/>
      <xs:element ref="longitude" minOccurs="0" maxOccurs="1"/>
      <xs:element ref="radius" minOccurs="0" maxOccurs="1"/>
      <xs:element ref="bearing" minOccurs="0" maxOccurs="1"/>
      <xs:element ref="range" minOccurs="0" maxOccurs="1"/>
      <xs:element ref="gusts" minOccurs="0" maxOccurs="1"/>
      <xs:element ref="gustAvgPeriod" minOccurs="0" maxOccurs="1"/>
      <xs:element ref="accuracy" minOccurs="0" maxOccurs="1"/>
    </xs:all>
    <xs:attribute name="source" use="optional" type="sourceType"/>
  </xs:complexType>
</xs:element>

<xs:element name="speed" nillable="true">
  <xs:complexType>
```

Cyclone XML Specification

```
<xs:simpleContent>
  <xs:extension base="anyNumber">
    <xs:attribute name="units" use="required" type="xs:normalizedString"/>
    <xs:attribute name="precision" use="optional" type="anyNumber"/>
  </xs:extension>
</xs:simpleContent>
</xs:complexType>
</xs:element>

<xs:element name="averagingPeriod" nillable="true">
  <xs:complexType>
    <xs:simpleContent>
      <xs:extension base="anyNumber">
        <xs:attribute name="units" use="required" type="xs:normalizedString"/>
      </xs:extension>
    </xs:simpleContent>
  </xs:complexType>
</xs:element>

<xs:element name="radius" nillable="true">
  <xs:annotation>
    <xs:documentation>Radial distance at which a threshold value is met.
    This can be within a particular sector or around the full circle.
    Sector must be specified (NEQ, SWQ, etc., or AAA for full circle).
    Default sector is "AAA"</xs:documentation>
  </xs:annotation>
  <xs:complexType>
    <xs:simpleContent>
      <xs:extension base="anyNumber">
        <xs:attribute name="units" use="required" type="xs:normalizedString"/>
        <xs:attribute name="precision" use="optional" type="anyNumber"/>
        <xs:attribute name="source" use="optional" type="sourceType"/>
        <xs:attribute name="sector" use="optional" type="sectorType"/>
      </xs:extension>
    </xs:simpleContent>
  </xs:complexType>
</xs:element>

<xs:element name="bearing" nillable="true">
  <xs:complexType>
    <xs:simpleContent>
      <xs:extension base="anyNumber">
        <xs:attribute name="units" use="required" type="xs:normalizedString"/>
        <xs:attribute name="precision" use="optional" type="anyNumber"/>
      </xs:extension>
    </xs:simpleContent>
  </xs:complexType>
</xs:element>

<xs:element name="range" nillable="true">
  <xs:complexType>
    <xs:simpleContent>
      <xs:extension base="anyNumber">
        <xs:attribute name="units" use="required" type="xs:normalizedString"/>
        <xs:attribute name="precision" use="optional" type="anyNumber"/>
      </xs:extension>
    </xs:simpleContent>
  </xs:complexType>
</xs:element>
```

Cyclone XML Specification

```
</xs:element>

<xs:element name="gusts" nillable="true">
  <xs:complexType>
    <xs:simpleContent>
      <xs:extension base="anyNumber">
        <xs:attribute name="units" use="required" type="xs:normalizedString"/>
        <xs:attribute name="precision" use="optional" type="anyNumber"/>
      </xs:extension>
    </xs:simpleContent>
  </xs:complexType>
</xs:element>

<xs:element name="gustAvgPeriod" nillable="true">
  <xs:complexType>
    <xs:simpleContent>
      <xs:extension base="anyNumber">
        <xs:attribute name="units" use="required" type="xs:normalizedString"/>
      </xs:extension>
    </xs:simpleContent>
  </xs:complexType>
</xs:element>

<xs:element name="maxFlightLevelWind">
  <xs:annotation>
    <xs:documentation>Data describing the storm's maximum sustained wind speed at
flight level</xs:documentation>
  </xs:annotation>
  <xs:complexType>
    <xs:all>
      <xs:element ref="speed"/>
      <xs:element ref="averagingPeriod" minOccurs="0" maxOccurs="1"/>
      <xs:element ref="accuracy" minOccurs="0" maxOccurs="1"/>
      <xs:element ref="directionToward" minOccurs="0" maxOccurs="1"/>
      <xs:element ref="bearing" minOccurs="0" maxOccurs="1"/>
      <xs:element ref="range" minOccurs="0" maxOccurs="1"/>
    </xs:all>
  </xs:complexType>
</xs:element>

<xs:element name="temperature">
  <xs:annotation>
    <xs:documentation>Temperatures in the storm and nearby
environment</xs:documentation>
  </xs:annotation>
  <xs:complexType>
    <xs:all>
      <xs:element ref="accuracy" minOccurs="0" maxOccurs="1"/>
      <xs:element ref="tempOutsideEye" minOccurs="0" maxOccurs="1"/>
      <xs:element ref="tempInsideEye" minOccurs="0" maxOccurs="1"/>
      <xs:element ref="dewpointTemperature" minOccurs="0" maxOccurs="1"/>
      <xs:element ref="seaSurfaceTemperature" minOccurs="0" maxOccurs="1"/>
    </xs:all>
  </xs:complexType>
</xs:element>

<xs:element name="tempOutsideEye" nillable="true">
  <xs:complexType>
```

Cyclone XML Specification

```
<xs:simpleContent>
  <xs:extension base="anyNumber">
    <xs:attribute name="units" use="required" type="xs:normalizedString"/>
  </xs:extension>
</xs:simpleContent>
</xs:complexType>
</xs:element>

<xs:element name="tempInsideEye" nillable="true">
  <xs:complexType>
    <xs:simpleContent>
      <xs:extension base="anyNumber">
        <xs:attribute name="units" use="required" type="xs:normalizedString"/>
      </xs:extension>
    </xs:simpleContent>
  </xs:complexType>
</xs:element>

<xs:element name="dewpointTemperature" nillable="true">
  <xs:complexType>
    <xs:simpleContent>
      <xs:extension base="anyNumber">
        <xs:attribute name="units" use="required" type="xs:normalizedString"/>
      </xs:extension>
    </xs:simpleContent>
  </xs:complexType>
</xs:element>

<xs:element name="seaSurfaceTemperature" nillable="true">
  <xs:complexType>
    <xs:simpleContent>
      <xs:extension base="anyNumber">
        <xs:attribute name="units" use="required" type="xs:normalizedString"/>
      </xs:extension>
    </xs:simpleContent>
  </xs:complexType>
</xs:element>

<xs:element name="minimumPressure" nillable="true">
  <xs:annotation>
    <xs:documentation>Minimum sea level pressure</xs:documentation>
  </xs:annotation>
  <xs:complexType>
    <xs:all>
      <xs:element ref="pressure"/>
      <xs:element ref="accuracy" minOccurs="0" maxOccurs="1"/>
    </xs:all>
    <xs:attribute name="source" use="optional" type="sourceType"/>
  </xs:complexType>
</xs:element>

<xs:element name="lastClosedIsobar">
  <xs:annotation>
    <xs:documentation>Data describing the pressure and radius of the last closed
isobar</xs:documentation>
  </xs:annotation>
  <xs:complexType>
    <xs:all>
```

Cyclone XML Specification

```
<xs:element ref="pressure"/>
<xs:element ref="radius" minOccurs="0" maxOccurs="1"/>
</xs:all>
</xs:complexType>
</xs:element>

<xs:element name="pressure" nillable="true">
  <xs:complexType>
    <xs:simpleContent>
      <xs:extension base="anyNumber">
        <xs:attribute name="units" use="required" type="xs:normalizedString"/>
        <xs:attribute name="precision" use="optional" type="anyNumber"/>
      </xs:extension>
    </xs:simpleContent>
  </xs:complexType>
</xs:element>

<xs:element name="eye">
  <xs:annotation>
    <xs:documentation>Data describing the cyclone's eye</xs:documentation>
  </xs:annotation>
  <xs:complexType>
    <xs:all>
      <xs:element ref="shape" minOccurs="0" maxOccurs="1"/>
      <xs:element ref="orientation" minOccurs="0" maxOccurs="1"/>
      <xs:element ref="diameter" minOccurs="0" maxOccurs="1"/>
      <xs:element ref="shortAxis" minOccurs="0" maxOccurs="1"/>
      <xs:element ref="wallCloudThickness" minOccurs="0" maxOccurs="1"/>
      <xs:element ref="percentWallObserved" minOccurs="0" maxOccurs="1"/>
    </xs:all>
  </xs:complexType>
</xs:element>

<xs:element name="shape" nillable="true">
  <xs:annotation>
    <xs:documentation>Shape of the cyclone's eye</xs:documentation>
  </xs:annotation>
  <xs:simpleType>
    <xs:restriction base="xs:string">
      <xs:enumeration value="circular"/>
      <xs:enumeration value="elliptic"/>
      <xs:enumeration value="concentric"/>
    </xs:restriction>
  </xs:simpleType>
</xs:element>

<xs:element name="orientation" nillable="true">
  <xs:complexType>
    <xs:simpleContent>
      <xs:extension base="anyNumber">
        <xs:attribute name="units" use="required" type="xs:normalizedString"/>
        <xs:attribute name="precision" use="optional" type="anyNumber"/>
      </xs:extension>
    </xs:simpleContent>
  </xs:complexType>
</xs:element>

<xs:element name="diameter" nillable="true">
```

Cyclone XML Specification

```
<xs:annotation>
  <xs:documentation>If storm is elliptic then this element describes the long
axis</xs:documentation>
</xs:annotation>
<xs:complexType>
  <xs:simpleContent>
    <xs:extension base="anyNumber">
      <xs:attribute name="units" use="required" type="xs:normalizedString"/>
      <xs:attribute name="precision" use="optional" type="anyNumber"/>
    </xs:extension>
  </xs:simpleContent>
</xs:complexType>
</xs:element>

<xs:element name="shortAxis" nillable="true">
  <xs:annotation>
    <xs:documentation>If storm is not elliptic then omit this
element</xs:documentation>
  </xs:annotation>
  <xs:complexType>
    <xs:simpleContent>
      <xs:extension base="anyNumber">
        <xs:attribute name="units" use="required" type="xs:normalizedString"/>
        <xs:attribute name="precision" use="optional" type="anyNumber"/>
      </xs:extension>
    </xs:simpleContent>
  </xs:complexType>
</xs:element>

<xs:element name="wallCloudThickness" nillable="true">
  <xs:complexType>
    <xs:simpleContent>
      <xs:extension base="anyNumber">
        <xs:attribute name="units" use="required" type="xs:normalizedString"/>
      </xs:extension>
    </xs:simpleContent>
  </xs:complexType>
</xs:element>

<xs:element name="percentWallObserved" type="anyNumber" nillable="true"/>

<xs:element name="spiralOverlay" nillable="true">
  <xs:complexType>
    <xs:simpleContent>
      <xs:extension base="anyNumber">
        <xs:attribute name="units" use="required" type="xs:normalizedString"/>
      </xs:extension>
    </xs:simpleContent>
  </xs:complexType>
</xs:element>

<xs:element name="cyclonePhase">
  <xs:annotation>
    <xs:documentation>Data on cyclone phase from Hart et al.
1993</xs:documentation>
  </xs:annotation>
  <xs:complexType>
    <xs:all>
```

Cyclone XML Specification

```

    <xs:element ref="stormRelThkSymmetry"/>
    <xs:element ref="thermalWindLower"/>
    <xs:element ref="thermalWindUpper"/>
  </xs:all>
</xs:complexType>
</xs:element>

<xs:element name="stormRelThkSymmetry" nillable="true">
  <xs:complexType>
    <xs:simpleContent>
      <xs:extension base="anyNumber">
        <xs:attribute name="units" use="required" type="xs:normalizedString"/>
      </xs:extension>
    </xs:simpleContent>
  </xs:complexType>
</xs:element>

<xs:element name="thermalWindLower" nillable="true">
  <xs:complexType>
    <xs:simpleContent>
      <xs:extension base="anyNumber">
        <xs:attribute name="units" use="required" type="xs:normalizedString"/>
      </xs:extension>
    </xs:simpleContent>
  </xs:complexType>
</xs:element>

<xs:element name="thermalWindUpper" nillable="true">
  <xs:complexType>
    <xs:simpleContent>
      <xs:extension base="anyNumber">
        <xs:attribute name="units" use="required" type="xs:normalizedString"/>
      </xs:extension>
    </xs:simpleContent>
  </xs:complexType>
</xs:element>

<xs:element name="stormMotion">
  <xs:annotation>
    <xs:documentation>Data describing the storm's speed and
direction</xs:documentation>
  </xs:annotation>
  <xs:complexType>
    <xs:all>
      <xs:element ref="speed"/>
      <xs:element ref="directionToward"/>
      <xs:element ref="speedAccuracy" minOccurs="0" maxOccurs="1"/>
      <xs:element ref="directionAccuracy" minOccurs="0" maxOccurs="1"/>
    </xs:all>
  </xs:complexType>
</xs:element>

<xs:element name="directionToward" nillable="true">
  <xs:complexType>
    <xs:simpleContent>
      <xs:extension base="anyNumber">
        <xs:attribute name="units" use="required" type="xs:normalizedString"/>
        <xs:attribute name="precision" use="optional" type="anyNumber"/>
      </xs:extension>
    </xs:simpleContent>
  </xs:complexType>
</xs:element>

```

Cyclone XML Specification

```
        </xs:extension>
    </xs:simpleContent>
</xs:complexType>
</xs:element>

<xs:element name="maximumPrecipitation">
    <xs:annotation>
        <xs:documentation>Data describing the storm's maximum
precipitation</xs:documentation>
    </xs:annotation>
    <xs:complexType>
        <xs:all>
            <xs:element ref="intensity"/>
            <xs:element ref="accuracy" minOccurs="0" maxOccurs="1"/>
            <xs:element ref="latitude" minOccurs="0" maxOccurs="1"/>
            <xs:element ref="longitude" minOccurs="0" maxOccurs="1"/>
            <xs:element ref="precipitationType" minOccurs="0" maxOccurs="1"/>
        </xs:all>
    </xs:complexType>
</xs:element>

<xs:element name="intensity" nillable="true">
    <xs:complexType>
        <xs:simpleContent>
            <xs:extension base="anyNumber">
                <xs:attribute name="units" use="required" type="xs:normalizedString"/>
                <xs:attribute name="precision" use="optional" type="anyNumber"/>
            </xs:extension>
        </xs:simpleContent>
    </xs:complexType>
</xs:element>

<xs:element name="precipitationType" nillable="true">
    <xs:annotation>
        <xs:documentation>Dominant precipitation type. If neither
"rain" nor "snow" then use "mixed"</xs:documentation>
    </xs:annotation>
    <xs:simpleType>
        <xs:restriction base="xs:string">
            <xs:enumeration value="rain"/>
            <xs:enumeration value="snow"/>
            <xs:enumeration value="mixed"/>
        </xs:restriction>
    </xs:simpleType>
</xs:element>

<xs:element name="maximumWaveHeight">
    <xs:annotation>
        <xs:documentation>Data describing the storm's maximum wave
height</xs:documentation>
    </xs:annotation>
    <xs:complexType>
        <xs:all>
            <xs:element ref="height"/>
            <xs:element ref="accuracy" minOccurs="0" maxOccurs="1"/>
            <xs:element ref="latitude" minOccurs="0" maxOccurs="1"/>
            <xs:element ref="longitude" minOccurs="0" maxOccurs="1"/>
        </xs:all>
    </xs:complexType>
</xs:element>
```

Cyclone XML Specification

```
</xs:complexType>
</xs:element>

<xs:element name="height">
  <xs:complexType>
    <xs:simpleContent>
      <xs:extension base="anyNumber">
        <xs:attribute name="units" use="required" type="xs:normalizedString"/>
        <xs:attribute name="precision" use="optional" type="anyNumber"/>
      </xs:extension>
    </xs:simpleContent>
  </xs:complexType>
</xs:element>

<xs:element name="windContours">
  <xs:complexType>
    <xs:sequence>
      <xs:element ref="windSpeed" minOccurs="1" maxOccurs="unbounded"/>
    </xs:sequence>
  </xs:complexType>
</xs:element>

<xs:element name="windSpeed">
  <xs:complexType mixed="true">
    <xs:sequence>
      <xs:element ref="radius" minOccurs="1" maxOccurs="unbounded"/>
    </xs:sequence>
    <xs:attribute name="units" use="required" type="xs:normalizedString"/>
  </xs:complexType>
</xs:element>

<xs:element name="seaContours">
  <xs:complexType>
    <xs:sequence>
      <xs:element ref="waveHeight" minOccurs="1" maxOccurs="unbounded"/>
    </xs:sequence>
  </xs:complexType>
</xs:element>

<xs:element name="waveHeight">
  <xs:complexType mixed="true">
    <xs:sequence>
      <xs:element ref="radius" minOccurs="1" maxOccurs="unbounded"/>
    </xs:sequence>
    <xs:attribute name="units" use="required" type="xs:normalizedString"/>
  </xs:complexType>
</xs:element>

<xs:element name="fixedRadii">
  <xs:complexType>
    <xs:sequence>
      <xs:element ref="fixedRadius" minOccurs="1" maxOccurs="unbounded"/>
    </xs:sequence>
  </xs:complexType>
</xs:element>

<xs:element name="fixedRadius">
  <xs:complexType mixed="true">
    <xs:all>
```

Cyclone XML Specification

```
<xs:element ref="pressure" minOccurs="0" maxOccurs="1"/>
<xs:element ref="tangentialWind" minOccurs="0" maxOccurs="1"/>
</xs:all>
<xs:attribute name="units" use="required" type="xs:normalizedString"/>
</xs:complexType>
</xs:element>

<xs:element name="tangentialWind" nillable="true">
  <xs:complexType>
    <xs:simpleContent>
      <xs:extension base="anyNumber">
        <xs:attribute name="units" use="required" type="xs:normalizedString"/>
        <xs:attribute name="precision" use="optional" type="anyNumber"/>
      </xs:extension>
    </xs:simpleContent>
  </xs:complexType>
</xs:element>

<xs:element name="comments" type="xs:string">
  <xs:annotation>
    <xs:documentation>Any comments can be inserted here</xs:documentation>
  </xs:annotation>
</xs:element>

<xs:element name="accuracy" nillable="true">
  <xs:complexType>
    <xs:simpleContent>
      <xs:extension base="anyNumber">
        <xs:attribute name="units" use="required" type="xs:normalizedString"/>
      </xs:extension>
    </xs:simpleContent>
  </xs:complexType>
</xs:element>

<xs:element name="speedAccuracy" nillable="true">
  <xs:complexType>
    <xs:simpleContent>
      <xs:extension base="anyNumber">
        <xs:attribute name="units" use="required" type="xs:normalizedString"/>
      </xs:extension>
    </xs:simpleContent>
  </xs:complexType>
</xs:element>

<xs:element name="directionAccuracy" nillable="true">
  <xs:complexType>
    <xs:simpleContent>
      <xs:extension base="anyNumber">
        <xs:attribute name="units" use="required" type="xs:normalizedString"/>
      </xs:extension>
    </xs:simpleContent>
  </xs:complexType>
</xs:element>

<xs:simpleType name="dataType">
  <xs:restriction base="xs:string">
    <xs:enumeration value="analysis"/>
    <xs:enumeration value="forecast"/>
  </xs:restriction>
</xs:simpleType>
```

Cyclone XML Specification

```
<xs:enumeration value="ensembleForecast" />
</xs:restriction>
</xs:simpleType>

<xs:simpleType name="perturbType">
  <xs:restriction base="xs:string">
    <xs:enumeration value="control" />
    <xs:enumeration value="positive" />
    <xs:enumeration value="negative" />
    <xs:enumeration value="simplex" />
    <xs:enumeration value="other" />
  </xs:restriction>
</xs:simpleType>

<xs:simpleType name="IDtype">
  <xs:restriction base="xs:string">
    <xs:pattern value="[0-9]{10}_[0-9]?[0-9]{2}[NS]_[0-9]?[0-9]?[0-9]{2}[EW]" />
  </xs:restriction>
</xs:simpleType>

<xs:simpleType name="TnumberType">
  <xs:restriction base="xs:string">
    <xs:pattern value="(T|ST|XT)?[0-8].[0-9]" />
  </xs:restriction>
</xs:simpleType>

<xs:simpleType name="sectorType">
  <xs:restriction base="xs:string">
    <xs:enumeration value="AAA" />
    <xs:enumeration value="full circle" />
    <xs:enumeration value="NNS" />
    <xs:enumeration value="north semicircle" />
    <xs:enumeration value="NES" />
    <xs:enumeration value="northeast semicircle" />
    <xs:enumeration value="EES" />
    <xs:enumeration value="east semicircle" />
    <xs:enumeration value="SES" />
    <xs:enumeration value="southeast semicircle" />
    <xs:enumeration value="SSS" />
    <xs:enumeration value="south semicircle" />
    <xs:enumeration value="SWS" />
    <xs:enumeration value="southwest semicircle" />
    <xs:enumeration value="WWS" />
    <xs:enumeration value="west semicircle" />
    <xs:enumeration value="NWS" />
    <xs:enumeration value="northwest semicircle" />
    <xs:enumeration value="NNQ" />
    <xs:enumeration value="north quadrant" />
    <xs:enumeration value="NEQ" />
    <xs:enumeration value="northeast quadrant" />
    <xs:enumeration value="EEQ" />
    <xs:enumeration value="east quadrant" />
    <xs:enumeration value="SEQ" />
    <xs:enumeration value="southeast quadrant" />
    <xs:enumeration value="SSQ" />
    <xs:enumeration value="south quadrant" />
    <xs:enumeration value="SWQ" />
    <xs:enumeration value="southwest quadrant" />
  </xs:restriction>
</xs:simpleType>
```

Cyclone XML Specification

```
<xs:enumeration value="WWQ" />
<xs:enumeration value="west quadrant" />
<xs:enumeration value="NWQ" />
<xs:enumeration value="northwest quadrant" />
</xs:restriction>
</xs:simpleType>

<xs:simpleType name="sourceType">
  <xs:restriction base="xs:string">
    <xs:enumeration value="satellite" />
    <xs:enumeration value="aircraft" />
    <xs:enumeration value="dropsonde" />
    <xs:enumeration value="radar" />
    <xs:enumeration value="synoptic" />
    <xs:enumeration value="Dvorak" />
    <xs:enumeration value="outer closed isobar" />
    <xs:enumeration value="poorly defined eye" />
    <xs:enumeration value="over water observation" />
    <xs:enumeration value="over land observation" />
    <xs:enumeration value="other" />
  </xs:restriction>
</xs:simpleType>

<xs:simpleType name="noTrail0">
  <xs:restriction base="xs:string">
    <xs:pattern value="[0-9]*\." />
  </xs:restriction>
</xs:simpleType>
<xs:simpleType name="anyNumber">
  <xs:union memberTypes="xs:integer xs:decimal noTrail0" />
</xs:simpleType>
</xs:schema>
```

5 CXML sample files

The same cyclone data is encoded here as if derived from analyzed data, a manual forecast, a NWP model, and an ensemble prediction system. For brevity only one disturbance (cyclone), and one fix (data corresponding to a particular time) are shown. Normally data corresponding to several fixes would be given. In the case of a global NWP model or EPS there may be several disturbances.

The headers shown in these examples contain essential metadata along with a reference to more complete metadata resident elsewhere. Many of the elements in header segment and most of the elements in the data segment are optional, allowing the CXML files to be brief or extensive as the application requires.

5.1 Tropical cyclone analysis

```
<?xml version="1.0" encoding="UTF-8"?>
<cxml xmlns:xsi="http://www.w3.org/2001/XMLSchema-instance"
xsi:noNamespaceSchemaLocation=
"http://www.bom.gov.au/bmrc/projects/THORPEX/CXML/cxml.1.0.xsd">

  <header>
    <product>Cyclone Analysis</product>
    <generatingApplication>
      <applicationType>Manual hurricane analysis</applicationType>
    </generatingApplication>
    <productionCenter>NWS
      <subCenter>National Hurricane Center</subCenter>
    </productionCenter>
    <moreInfo>http://www.nhc.noaa.gov/</moreInfo>
    <moreMetadata>http://www.nhc.noaa.gov/TCanal/metadata.html</moreMetadata>
    <baseTime>2007-07-25T12:00:00Z</baseTime>
    <creationTime>2007-07-25T15:42:00</creationTime>
  </header>

  <data type="analysis">
    <disturbance ID="2007072518_134N_1102E">
      <cycloneName>George</cycloneName>
      <cycloneNumber>1</cycloneNumber>
      <localID>NHC0001</localID>
      <basin>Southern Hemisphere</basin>
      <fix hour="0">
        <validTime>2007-07-25T12:00:00Z</validTime>
        <latitude units="deg N">13.2</latitude>
        <longitude units="deg E">110.0</longitude>
        <accuracy units="deg">0.3</accuracy>
        <cycloneData biasCorrected="false">
          <development>tropical cyclone</development>
          <category>2</category>
          <Dvorak>
            <finalTnumber>3.0</finalTnumber>
            <currentIntensity>3.0</currentIntensity>
            <pastChange>D1.0</pastChange>
            <changePeriod units="h">24</changePeriod>
          </Dvorak>
          <eye>
            <shape>circular</shape>
            <diameter units="km">35.</diameter>
          </eye>
          <minimumPressure source="Dvorak">
```

Cyclone XML Specification

```
    <pressure units="hPa" precision="1.">989.</pressure>
    <accuracy units="hPa">0.5</accuracy>
  </minimumPressure>
  <maximumWind>
    <speed units="m/s" precision="0.2">49.8</speed>
    <averagingPeriod units="min">10.</averagingPeriod>
    <latitude units="deg N">13.24</latitude>
    <longitude units="deg E">110.13</longitude>
    <radius units="km">25.2</radius>
    <accuracy units="m/s">2.</accuracy>
  </maximumWind>
  <maxSeas units="m">40.</maxSeas>
  <windContours>
    <windSpeed units="kt">34
      <radius sector="AAA" units="km">235.</radius>
      <radius sector="NEQ" units="km">200.</radius>
      <radius sector="SEQ" units="km">243.</radius>
      <radius sector="SWQ" units="km">301.</radius>
      <radius sector="NWQ" units="km">228.</radius>
    </windSpeed>
    <windSpeed units="kt">50
      <radius sector="NEQ" units="km">159.</radius>
      <radius sector="SEQ" units="km">138.</radius>
      <radius sector="SWQ" units="km">121.</radius>
      <radius sector="NWQ" units="km">107.</radius>
    </windSpeed>
    <windSpeed units="kt">63
      <radius sector="AAA" units="km">64.</radius>
    </windSpeed>
  </windContours>
  <seaContours>
    <waveHeight units="m">10
      <radius sector="AAA" units="km">200.</radius>
    </waveHeight>
    <waveHeight units="m">20
      <radius sector="AAA" units="km">120.</radius>
    </waveHeight>
  </seaContours>
</cycloneData>
</fix>
</disturbance>
</data>
</cxml>
```

5.2 Tropical cyclone forecast

The metadata specifies the source of the forecast. The data content is essentially the same as above, but the <data> tag now specifies type="forecast" instead of type="analysis".

```
<?xml version="1.0" encoding="UTF-8"?>
<cxml xmlns:xsi="http://www.w3.org/2001/XMLSchema-instance"
xsi:noNamespaceSchemaLocation=
"http://www.bom.gov.au/bmrc/projects/THORPEX/CXML/cxml.1.0.xsd">

  <header>
    <product>Cyclone Forecast</product>
    <generatingApplication>
      <applicationType>Subjective hurricane forecast</applicationType>
    </generatingApplication>
    <productionCenter>NWS
      <subCenter>National Hurricane Center</subCenter>
    </productionCenter>
```

Cyclone XML Specification

```
<moreInfo>http://www.nhc.noaa.gov/</moreInfo>
<moreMetadata>http://www.nhc.noaa.gov/TCfcst/metadata.html</moreMetadata>
<baseTime>2007-07-25T12:00:00Z</baseTime>
<creationTime>2007-07-25T15:42:00</creationTime>
</header>

<data type="forecast">
  <disturbance ID="2007072518_134N_1102E">
    <cycloneName>George</cycloneName>
    <cycloneNumber>1</cycloneNumber>
    <localID>NHC0001</localID>
    <basin>Southern Hemisphere</basin>
    <objectiveTechnique>BLND</objectiveTechnique>
    <fix hour="6">
      <validTime>2007-07-25T18:00:00Z</validTime>
      <latitude units="deg N">13.2</latitude>
      <longitude units="deg E">110.0</longitude>
      <cycloneData biasCorrected="true">
        (etc...)
      </cycloneData>
    </fix>
  </disturbance>
</data>
</cxml>
```

5.3 Tropical cyclone forecast from NWP

This data is similar to the manual forecast above, but the header now includes information about the model. The forecast data includes an (optional) abbreviated analysis segment (<fix hour="0">) and cyclone phase information derived from upper level fields.

```
<?xml version="1.0" encoding="UTF-8"?>
<cxml xmlns:xsi="http://www.w3.org/2001/XMLSchema-instance"
xsi:noNamespaceSchemaLocation=
"http://www.bom.gov.au/bmrc/projects/THORPEX/CXML/cxml.1.0.xsd">

  <header>
    <product>Cyclone Forecast</product>
    <generatingApplication>
      <applicationType>Global spectral model</applicationType>
      <model>
        <name>ECMWF</name>
        <domain>global</domain>
        <modelResolution>T799</modelResolution>
        <dataResolution units="degrees">0.25</dataResolution>
      </model>
    </generatingApplication>
    <productionCenter>ECMWF
      <subCenter>Operations Division</subCenter>
    </productionCenter>
    <moreInfo>http://www.ecmwf.int/</moreInfo>
    <moreMetadata>http://www.ecmwf.int/ifs/metadata.html</moreMetadata>
    <baseTime>2007-07-25T12:00:00Z</baseTime>
    <creationTime>2007-07-25T15:42:00</creationTime>
  </header>

  <data type="forecast">
    <disturbance ID="2007072518_134N_1102E">
      <cycloneName>George</cycloneName>
      <cycloneNumber>1</cycloneNumber>
```

Cyclone XML Specification

```
<localID>IFS0001</localID>
<basin>Southern Hemisphere</basin>
<fix hour="0">
  <validTime>2007-07-25T12:00:00Z</validTime>
  <latitude units="deg N">13.2</latitude>
  <longitude units="deg E">110.0</longitude>
  <cycloneData biasCorrected="false">
    <development>tropical cyclone</development>
    <minimumPressure>
      <pressure units="hPa" precision="1.">989.</pressure>
      <accuracy units="hPa">0.5</accuracy>
    </minimumPressure>
    <maximumWind>
      <speed units="m/s" precision="0.2">49.8</speed>
      <averagingPeriod units="min">10.</averagingPeriod>
      <radius units="km">25.2</radius>
    </maximumWind>
  </cycloneData>
</fix>
<fix hour="6">
  <validTime>2007-07-25T18:00:00Z</validTime>
  <latitude units="deg N">13.2</latitude>
  <longitude units="deg E">110.0</longitude>
  <cycloneData biasCorrected="true">
```

(etc...)

```
    <cyclonePhase>
      <stormRelThkSymmetry units="hPa">50.</stormRelThkSymmetry>
      <thermalWindLower units="m/s">50.</thermalWindLower>
      <thermalWindUpper units="m/s">-250.</thermalWindUpper>
    </cyclonePhase>
  </cycloneData>
</fix>
</disturbance>
</data>
</cxml>
```

5.4 Ensemble TC forecast from NWP

The main changes from the NWP forecast above are the inclusion in the header of metadata about the ensemble, and the <data> tag now specifies that this is an ensemble forecast with attributes giving the ensemble member number and perturbation status. Information on storm maximum precipitation has been added to the forecast data.

```
<?xml version="1.0" encoding="UTF-8"?>
<cxml xmlns:xsi="http://www.w3.org/2001/XMLSchema-instance"
xsi:noNamespaceSchemaLocation=
"http://www.bom.gov.au/bmrc/projects/THORPEX/CXML/cxml.1.1.0.xsd">

  <header>
    <product>Cyclone Forecast</product>
    <generatingApplication>
      <applicationType>Global ensemble prediction system</applicationType>
      <model>
        <name>ECMWF</name>
        <domain>global</domain>
        <modelResolution>T399</modelResolution>
        <dataResolution units="degrees">0.5</dataResolution>
      </model>
      <ensemble>
        <numMembers>51</numMembers>
```

Cyclone XML Specification

```
    <perturbationMethod>SVD</perturbationMethod>
  </ensemble>
</generatingApplication>
<productionCenter>ECMWF
  <subCenter>Operations Division</subCenter>
</productionCenter>
<moreInfo>http://www.ecmwf.int/about/eps.html</moreInfo>
<moreMetadata>http://www.ecmwf.int/about/eps/metadata.html</moreMetadata>
<baseTime>2007-07-25T12:00:00Z</baseTime>
<creationTime>2007-07-25T15:42:00</creationTime>
</header>

<data type="ensembleForecast" member="0" perturb="control">
  <disturbance ID="2007072518_134N_1102E">
    <cycloneName>George</cycloneName>
    <cycloneNumber>1</cycloneNumber>
    <localID>EPS0001</localID>
    <basin>Southern Hemisphere</basin>
    <fix hour="0">
      <validTime>2007-07-25T12:00:00Z</validTime>
      <latitude units="deg N">13.2</latitude>
      <longitude units="deg E">110.0</longitude>
      <cycloneData biasCorrected="true">
        <development>tropical cyclone</development>
        <minimumPressure>
          <pressure units="hPa" precision="1.">989.</pressure>
          <accuracy units="hPa">0.5</accuracy>
        </minimumPressure>
        <maximumWind>
          <speed units="m/s" precision="0.2">49.8</speed>
          <averagingPeriod units="min">10.</averagingPeriod>
          <radius units="km">25.2</radius>
        </maximumWind>
      </cycloneData>
    </fix>
    <fix hour="6">
      <validTime>2007-07-25T18:00:00Z</validTime>
      <latitude units="deg N">13.2</latitude>
      <longitude units="deg E">110.0</longitude>
      <cycloneData biasCorrected="false">
        <maxPrecip>
          <intensity units="mm/h">68.</intensity>
          <latitude units="deg N">13.05</latitude>
          <longitude units="deg E">110.25</longitude>
          <precipType>rain</precipType>
        </maxPrecip>
      </cycloneData>
    </fix>
  </disturbance>
</data>
</cxml>
```

Appendix 1: Recommended data units in CXML

Although not enforced by the CXML schema, it is recommended that the units of measurement in CXML files adhere to the following standards to allow ease of recognition and conversion. Following ISO 31 SI units should be used where practical, and preferred abbreviations are indicated.

Table A1.1. Units of length

| Full name of units | Text abbreviation(s) |
|------------------------|----------------------|
| meter | m |
| kilometer | km |
| mile (non-SI) | mi |
| nautical mile (non-SI) | nm |
| degrees | deg |

Table A1.2. Units of time

| Full name of units | Text abbreviation(s) |
|--------------------|----------------------|
| second | s |
| minute | min |
| hour | h |
| day | d |

Table A1.3. Units of speed

| Full name of units | Text abbreviation(s) |
|---|--------------------------------------|
| meters per second | m/s (preferred), m s ⁻¹ |
| kilometers per hour | km/h (preferred), km h ⁻¹ |
| miles per hour (non-SI) | mi/h (preferred), mi h ⁻¹ |
| nautical miles per hour (knots) (non-SI but accepted for use in SI) | kt (preferred), kn |

Table A1.4. Units of geographical position (latitude and longitude)

| Full name of units | Text abbreviation(s) |
|--------------------|--|
| degrees | deg (longitudes between -180 to 180, positive east of the Greenwich meridian; latitudes between -90 and 90, positive north of the Equator) |
| degrees north | deg N |
| degrees south | deg S |
| degrees east | deg E |
| degrees west | deg W |

Table A1.5. Units of pressure

| Full name of units | Text abbreviation(s) |
|------------------------|----------------------|
| Pascal | Pa |
| hectopascal (millibar) | hPa (preferred), mb |

Table A1.6. Units of direction and angle

| Full name of units | Text abbreviation(s) |
|---|----------------------|
| degrees clockwise from true north | deg true |
| gradians (100 th of 90 degree angle) | grad |
| degrees | deg |
| radians | rad |

Cyclone XML Specification

Table A1.7. Units of precipitation rate

| Full name of units | Text abbreviation(s) |
|---------------------------|--------------------------------------|
| millimeters per hour | mm/h (preferred), mm h ⁻¹ |
| millimeters per day | mm/d (preferred), mm d ⁻¹ |
| meters per hour | m/h (preferred), m h ⁻¹ |
| meters per day | m/d (preferred), m d ⁻¹ |
| inches per hour (non-SI) | in/h (preferred), in h ⁻¹ |
| inches per day (non-SI) | in/d (preferred), in d ⁻¹ |

Table A1.8. Units of temperature

| Full name of units | Text abbreviation(s) |
|---------------------------|-----------------------------|
| Kelvin | K |
| Celsius | C |
| Fahrenheit (non-SI) | F |